

THE NEW DIMENSION OF WOOD

WOOD & MORE

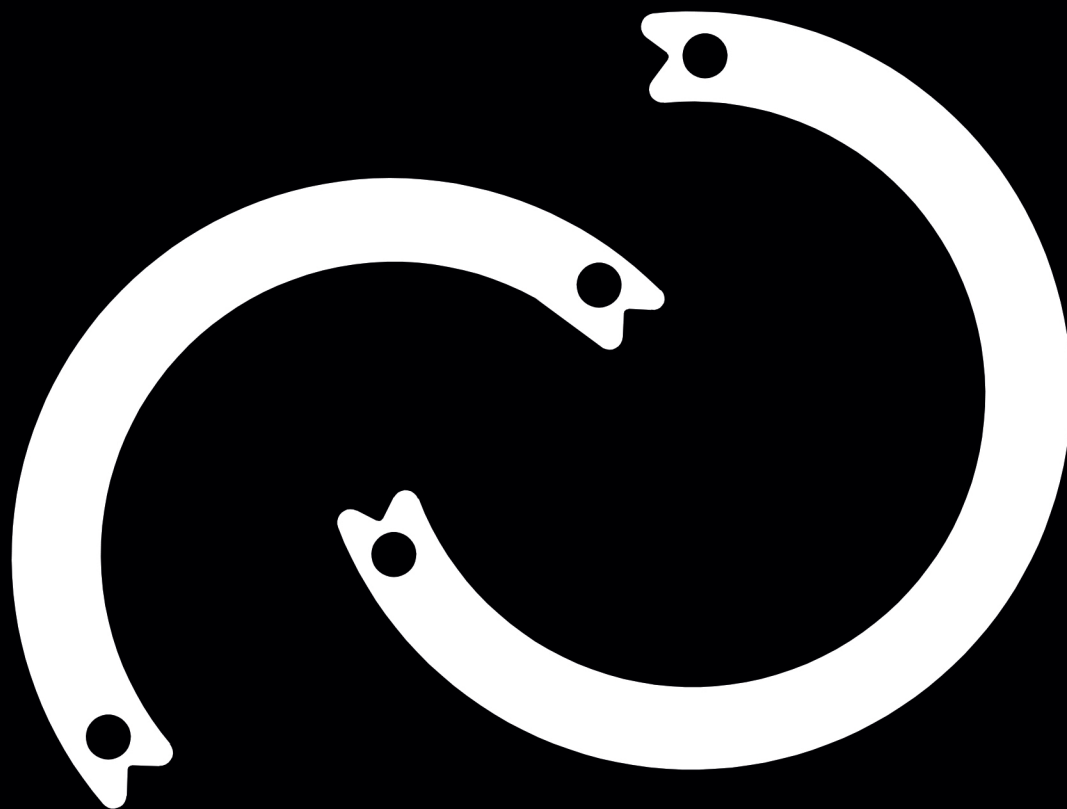

THE NEW DIMENSION OF WOOD

100% Made in Spain

WOOD+

LISTONE &
TAVOLE

CHEVRON

W+DESIGN

PALACE

WOODMOSAIC

TECHNICAL
FEATURES



Creativity, passion, and love for technology applied to design. This is the thought that moves a company like STP towards solutions that combine elegance and technological skills. STP offers a material which is unique with its characteristics and effects: wood. Several wood species modulated on a variety of formats: from planks with contemporary taste to new formats that allow special layouts and original combinations. Wood+, W+Listone & Tavole STP, Chevron, W+Design, and WoodMosaic series reveal geometries and soft lines to decorate cozy spaces because wood is not only a material... but much more.

Creatividad, pasión y gusto por la tecnología aplicada al diseño. Este es el pensamiento que mueve a una empresa como STP a la búsqueda de soluciones que combinan elegancia y habilidades tecnológicas. STP propone un material único por sus características y efectos. Diversas especies de madera moduladas en una gran variedad de formatos: desde listones con sabor contemporáneo a nuevos formatos particulares que permiten una composición especial y originales combinaciones. Las colecciones Wood+, W+Listone y Tavole STP, Chevron, W+Design y WoodMosaic revelan geometrías y líneas suaves para crear espacios acogedores porque la madera no es solo un material... sino mucho más.

Creatività, passione e gusto per la tecnologia applicata al design. Questo è il pensiero che muove un'azienda come STP verso soluzioni che sanno coniugare doti tecnologiche ed eleganza. STP propone un materiale unico per caratteristiche ed effetti. Diverse specie legnose modulate su una grande varietà di formati: dai listoni dal gusto contemporaneo, ai formati più particolari che permettono pose originali e giochi di intarsi. Le serie Wood+, W+Listone & Tavole STP, Chevron, W+Design e WoodMosaic svelano geometrie e segni morbidi per creare ambienti accoglienti, perché il legno non è solo un materiale... ma molto di più.

创意、激情和对将技术应用于设计的热爱。正是这种想法推动着STP这样的公司走向将优雅的产品和卓越的技术相结合的解决方案。STP提供了一种具有独特特性和效果的材料：木材。不同的木材品种可以制成不同的形状。由经典的直板到新的特殊形状组合成更多的创新形态。WOOD+方块系列、直板系列、鱼骨拼系列、异形系列以及马赛克系列等不同的系列展现出地板可以用几何形状，甚至更优美柔和的线条装饰出舒适的空间，因为，木材不仅仅是一种材料，它可以创造更多价值。



Wood is a surprising material thanks to its colors, textures, and nuances, with all the benefits of a fully natural material, which must be protected. STP is pursuing a concrete eco-sustainable policy, limiting waste and supporting the renewal of resources.

La madera es un material sorprendente por sus colores, texturas y matices, con todas las ventajas de un material completamente natural, que hay que proteger. STP lleva a cabo una política de sostenibilidad ecológica que limita el desperdicio y apoya la renovación de recursos.

Il legno è un materiale sorprendente per colori, sfumature e trame, con tutti i vantaggi di un elemento completamente naturale che, per questo, va protetto. STP porta avanti una concreta politica eco-sostenibile, che limita gli sprechi e sostiene il rinnovamento delle risorse.

由于其颜色、纹理和细微差别，木材是一种令人惊讶的材料，具有完全天然材料的所有好处，必须加以保护。STP正在推行切实的生态可持续政策，限制浪费和支持资源再生。

WOOD & MORE

A special meeting. Un encuentro especial. Un incontro speciale. 一场特别的奇遇



www.fsc.org
FSC® C122157

The mark of
responsible forestry

CERTIFICATION FSC®, which identifies the products containing wood originated from forests which are managed in a correct and responsible way according to rigorous environmental, social and economical standards. The originating forest is controlled and valued independently according to these standards (principles and rules for a good forest management) which are established and approved by the Forest Stewardship Council a.c. with the participation and the consent of the involved parts.FSC under request.

nwfa
National Wood
Flooring Association
MEMBER

INDEX

INDEX / INDICE / INDICE / 索引

p.06	LOCKSTP
p.08	SIZES
p.14	COLORS
p.18	FINISHES
p.22	WOOD+
p.54	W+LISTONE & TAVOLE STP
p.70	CHEVRON
p.86	W+DESIGN
p.120	PALACE
p.132	WOODMOAIC
p.148	TECHNICAL FEATURES

SYSTEM

SYSTEM / SISTEMA / SISTEMA / 系统

LOCKSTP®

EXCELLENT GLUELESS SYSTEM

Patent-protected worldwide



LockSTP is a world-wide patented system, based on alternating tongues and grooves in a modular size of 290 mm which, together with the precise interlocking rings, provide a perfect bond without the use of adhesives. An innovative glueless flooring system that allows unlimited and flexible unique designs every time.

LockSTP es un sistema patentado a nivel mundial, basado en un machihembrado alterno con un tamaño modular de 290 mm que, junto con las anillas de anclaje y su precisión, proporcionan una unión perfecta sin el uso de adhesivos. Un innovador sistema de suelo flotante que permite diseños únicos e ilimitados en todo momento.

LockSTP è un sistema brevettato a livello mondiale, basato sull'alternanza di maschio e femmina in una dimensione modulare di 290 mm che, insieme ai precisi anelli ad incastro, forniscono una perfetta unione senza l'uso di adesivi. Un innovativo sistema di pavimentazione glueless che consente ogni volta design unici illimitati e flessibili.

LockSTP是一种具有全球专利的安装系统，其模块化尺寸为290毫米，采用交错舌口和凹槽，加上精确的环型锁扣，无需使用粘合剂（胶水），即可实现完美的无胶安装。创新的无胶地板安装系统，让每一次地板安装都能满足无限灵活的独特设计。

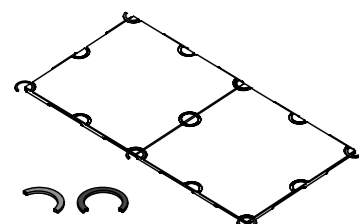

Modular system.
Sistema modular.
Sistema modulare.
模块化系统



Union rings for joint pieces.
Anillas para la unión de piezas.
Anelli per unione di pezzi.
用于连接部件的连接环



Covering hooks, for glueless wall applications.
Clip de revestimiento, para fijaciones en seco en pared.
Clips da rivestimento, per applicazioni a parete senza colla.
覆盖挂钩，用于墙面的无胶应用

STRUCTURE

ESTRUCTURA / STRUTTURA / 结构

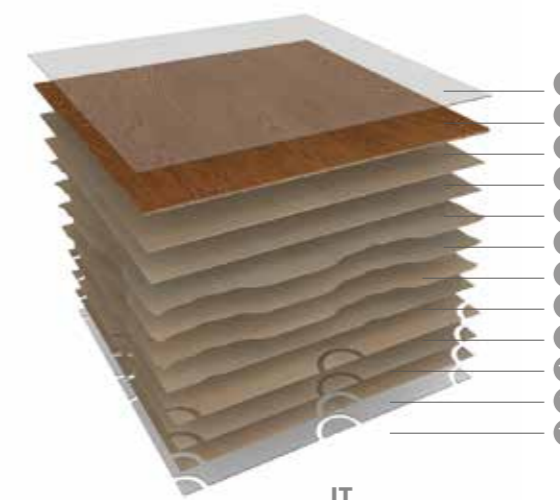

ENG

- 1st Overlay STP Classic. High-performance protective overlay consisting of up to 12 coats combining stained, primer, and protective varnish, to give the product a resistant finish and create an oil effect at the same time.
- 1st Layer. Noble wood of 3/4 mm thickness (depending on collection and finish), micro-beveled on all four sides.
- (3-11) Central Layer. Composed of 9 alternating layers of 100% birch plywood that works as an internal shaft and gives to the whole structure greater strength and stability (Thickness 12mm / 0.47").
- 2nd Overlay. Waterproofing varnish. Made of a layer of pore-filler varnish which helps to ensure the compact plan configuration of the piece.

ESP

- 1a Aplicación STP Classic. Capa protectora de alto rendimiento compuesta por hasta 12 aplicaciones que combinan tinte, imprimación y barniz protector, para dar al producto un acabado resistente y crear un efecto aceite al mismo tiempo.
- 1a Capa. Madera noble de 3/4 mm de espesor (según colección y acabado), micro-biselada en los cuatro lados.
- (3-11) Capa central. Compuesta por 9 capas alternas de contrachapado 100% abedul que funciona como eje interno y le da a toda la estructura una mayor resistencia y estabilidad (Espesor 12mm / 0.47").
- 2a Aplicación. Barniz impermeabilizante. Compuesto por una capa de barniz tapa poros que contribuye a garantizar la planimetría de la pieza.

IT

- 1a Applicazione STP Classic. Pellicola protettiva ad alte prestazioni composta da un massimo di 12 mani che combinano vernice per la colorazione, primer e protettiva, per conferire al prodotto una finitura resistente e creare allo stesso tempo un effetto olio.
- 1o Strato. Legno nobile di 3/4 mm spessore (a seconda della collezione e della finitura), micro-bisellato sui quattro lati.
- (3-11) Strato centrale. Composto da 9 strati alternati di multistrato di betulla 100% che hanno la funzione controbilanciante e conferisce a tutta la struttura maggiore resistenza e stabilità (Spessore 12mm / 0.47").
- 2o Applicazione. Vernice impermeabilizzante. Costituita da un strato di vernice per la chiusura dei pori che contribuisce a garantire la planarità del materiale.

CN

- 经典保护层：由多达12层的着色、底漆和保护清漆组成的高性能保护层，给产品一个耐磨保护层，同时创造一个油的效果。
- 第一层：3/4毫米名贵实木层（取决于优异的选材和表面加工），四边微倒角处理。
- 中间层（3-11）：由9层100%全桦木基材，纵横交错组成，使得整体结构超强坚韧及稳定（12mm厚度）。
- 底层：防水漆面处理。由一层孔隙填料清漆制成，有助于确保地板紧凑的平面配置。



SIZES

100% Made in Spain

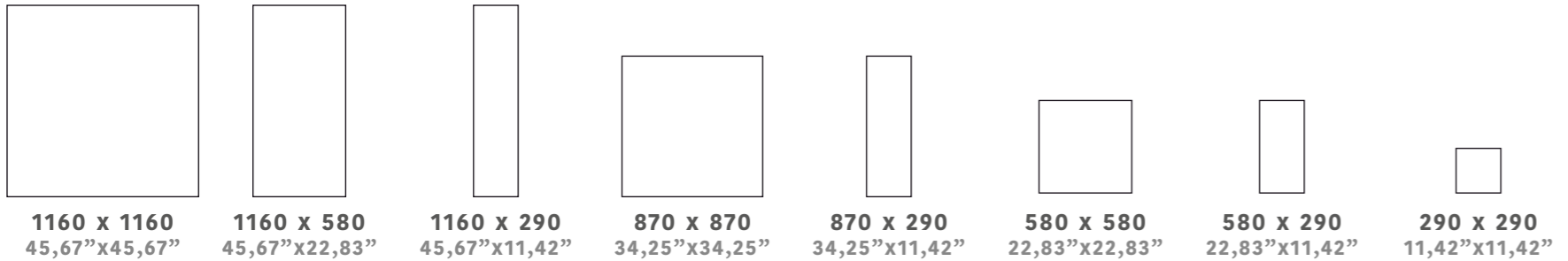

with LockSTP system, for floating installation

¹Regular orders to be in 2 MIXED LENGTHS of 2030-1740 MM. ²MIXED LENGTHS of 2030-1740-1450-1160 MM., available under request.
*Herringbone engineering, always 145 MM. width, available under request & subject to an extra cost.

con sistema LockSTP, para instalación flotante

¹Pedidos ordinarios con 2 LARGOS MIXTOS de 2030-1740 MM. ²LARGOS MIXTOS ALEATORIOS de 2030-1740-1450-1160 MM., disponibles bajo pedido.
*Mecanizado Herringbone, siempre ancho de 145 MM., disponible bajo pedido y sujeto a un cargo extra.

con sistema LockSTP, per installazione flottante

¹Ordini standard in 2 LUNGHEZZE MISTE di 2030-1740 MM. ²LUNGHEZZE MISTE (RANDOM) di 2030-1740-1450-1160 MM., disponibile su richiesta.
*Sistema herringbone, sempre in larghezza di 145 MM., disponibile su richiesta e soggetto a un costo adizionale.

使用LockSTP安装系统, 可无胶悬浮安装。

¹常规直板订单, 地板长度为两种规格, 2030毫米和1740毫米 ²混合不等长, 长度为2030-1740-1450-1160 毫米
*可做人字拼, 宽度为145毫米, 可定制, 需加收额外费用

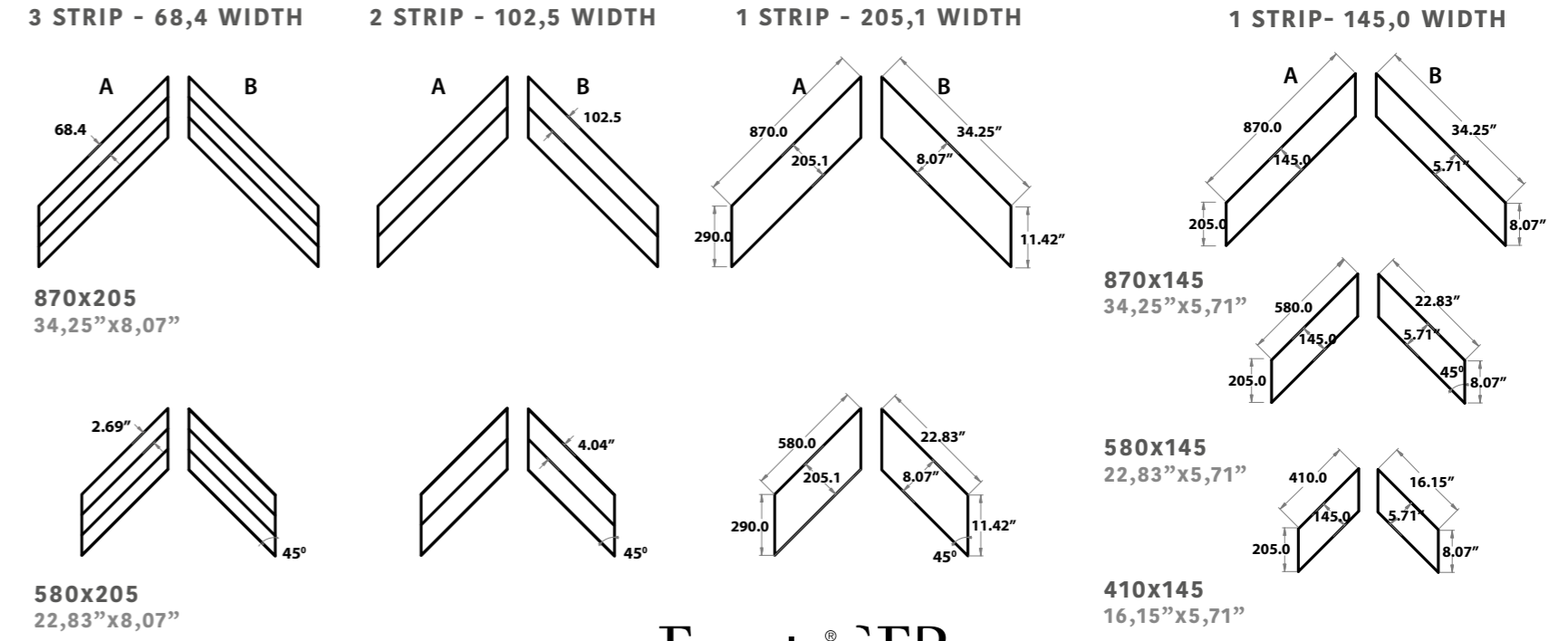
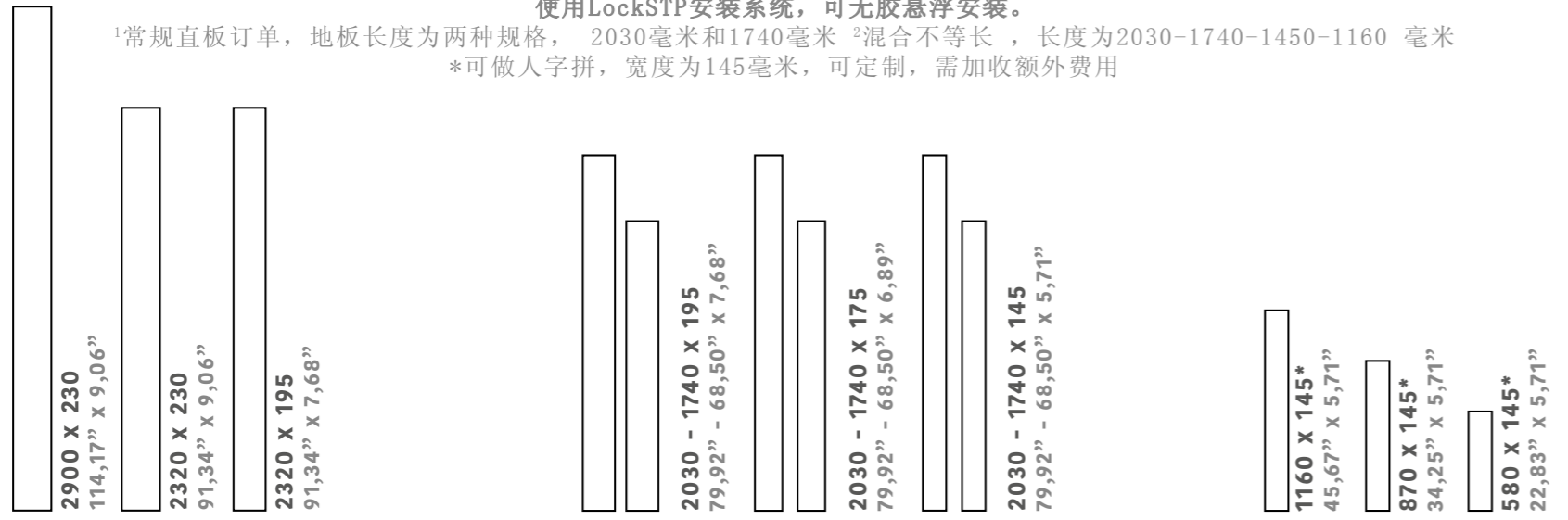

with traditional T&G system, for glue down installation

¹Regular orders to be in 2 MIXED LENGTHS of 2030-1740 MM. ²MIXED LENGTHS of 2030-1740-1450-1160 MM., available under request.
*Herringbone engineering, always 145 MM. width, available under request & subject to an extra cost.

con sistema tradicional T&G, para instalación encolada

¹Pedidos ordinarios con 2 LARGOS MIXTOS de 2030-1740 MM. ²LARGOS MIXTOS ALEATORIOS de 2030-1740-1450-1160 MM., disponibles bajo pedido.
*Mecanizado Herringbone, siempre ancho de 145 MM., disponible bajo pedido y sujeto a un cargo extra.

con sistema tradizionale T&G, per installazione incollata

¹Ordini standard in 2 LUNGHEZZE MISTE di 2030-1740 MM. ²LUNGHEZZE MISTE (RANDOM) di 2030-1740-1450-1160 MM., disponibile su richiesta.
*Sistema herringbone, sempre in larghezza di 145 MM., disponibile su richiesta e soggetto a un costo adizionale.

使用传统安装方式, 胶水安装

¹常规直板订单, 地板长度为两种规格, 2030毫米和1740毫米 ²混合不等长, 长度为2030-1740-1450-1160 毫米
*可做人字拼, 宽度为145毫米, 可定制, 需加收额外费用

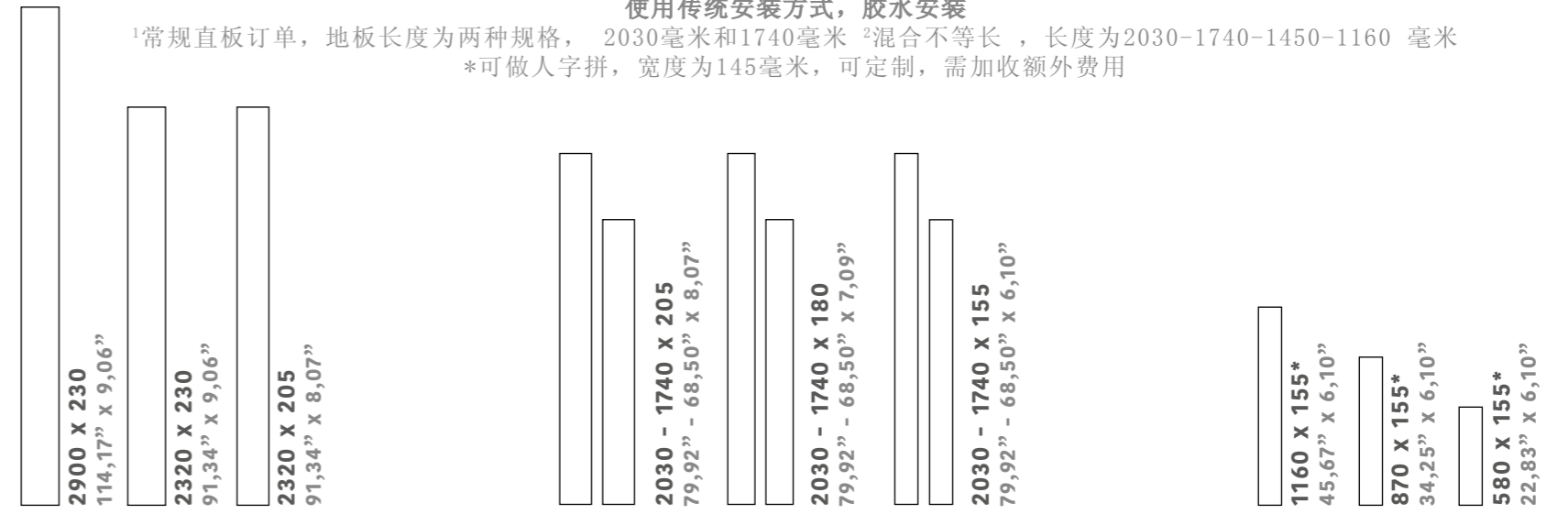

100% Made in Spain

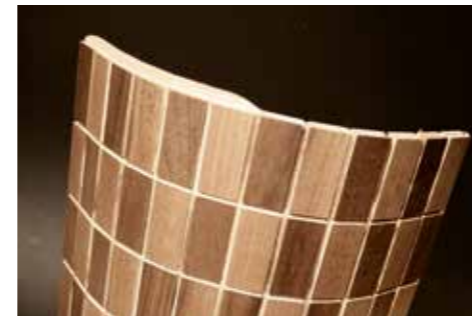

Flexible format available under request. Formato flexible disponible bajo pedido. Formato flessibile disponibile su richiesta 可定制尺寸

290 x 290
11,42"x11,42"

30 x 30
1,18"x1,18"

50 x 50
1,97"x1,97"

100 x 100
3,94"x3,94"

100 x 30
3,94"x1,18"

150 x 30
5,91"x1,18"

290 x 50
11,42"x1,97"

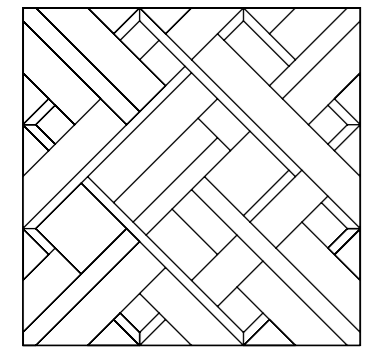

BOUCHERON
1160x1160
45,67"x45,67"

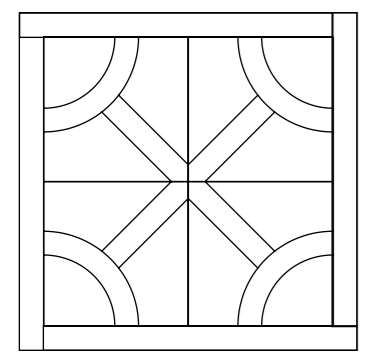

CHANTILLY
1160x1160 / 580x580
45,67"x45,67" / 22,83"x22,83"

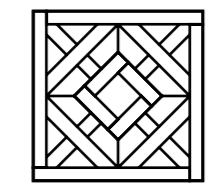

ALHAMBRA
580x580
22,83"x22,83"

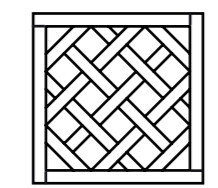

CAPODIMONTE
580x580
22,83"x22,83"

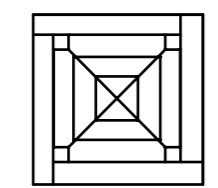

HERMITAGE
580x580
22,83"x22,83"

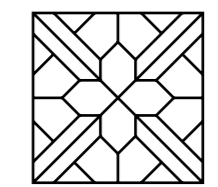

POTALA
580x580
22,83"x22,83"

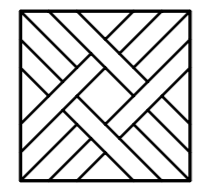

ARGYLE
580x580
22,83"x22,83"

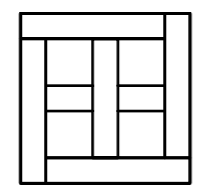

CROSS CASSETTE
580x580
22,83"x22,83"

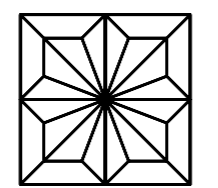

KUCUKSU
580x580
22,83"x22,83"

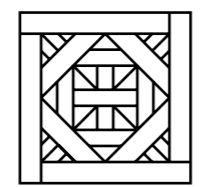

TAJ MAHAL
580x580
22,83"x22,83"

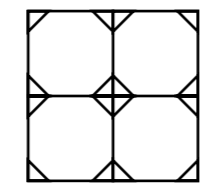

BEAUVALLON
580x580
22,83"x22,83"

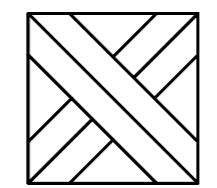

DOHA
580x580
22,83"x22,83"

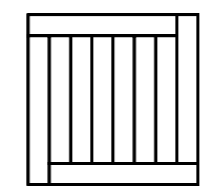

MONET
580x580
22,83"x22,83"

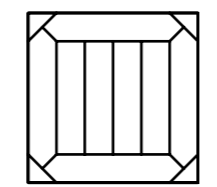

TOP KAPI
580x580
22,83"x22,83"

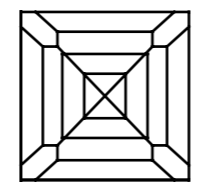

BUCKINGHAM
580x580
22,83"x22,83"

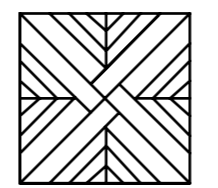

FONTAINEBLEAU
580x580
22,83"x22,83"

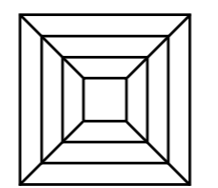

PALAIS ROYAL
580x580
22,83"x22,83"

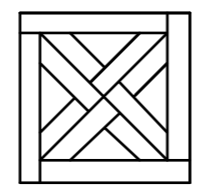

VERSAILLES
580x580
22,83"x22,83"

TRAPEZIUM 870
870x145
34,25"x5,71"

TRAPEZIUM 580
580x145
22,83"x5,71"

TRIANGLE
580x580
22,83"x22,83"

SILHOUETTE
580x783
22,83"x30,83"

DIAMOND
502x290
19,77"x11,42"

MORISCO
290x290
11,42"x11,42"

SQUAMA
290x290
11,42"x11,42"

TRENCADIS
1160x580
45,67"x22,83"

RHOMBUS
1160x290
45,67"x11,42"

MULTINE
870x290
34,25"x11,42"

MULTILINE
580x580
22,83"x22,83"

45°
580x580
22,83"x22,83"

DADOS
290x290
11,42"x11,42"

HEXAGON 580
580x502
22,83"x19,76"

HEXAGON 290
290x251
11,42"x9,88"

BRAID A / B
580x145
22,83"x5,71"

BRAID C
615x410
24,21"x16,14"

LOOPING 8
2030x230
79,92"x9,06"

MULTILINE

BICOLOR MAPLE NATURAL
A. WALNUT NATURAL
580x580
22,83"x22,83"

870x290
34,25"x11,42"

A. WALNUT NATURAL
580x580
22,83"x22,83"

870x290
34,25"x11,42"

INFINITY LINE
580x580
22,83"x22,83"

870x290
34,25"x11,42"

MULTI-RIGATO

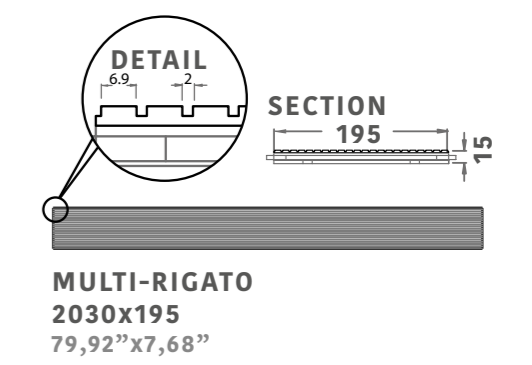



WOOD + COLORS

OAK

NEW



OAK AGED¹ OAK ANTICATO OAK ANTIQUE LAVA¹ OAK ASH OAK BACCARAT² OAK BLACK PEARL (matt/shine) OAK BORGHETTO OAK BOTANIC



OAK BROWN OAK BRUNELLO OAK BRUNELLO DARK OAK COGNAC OAK DEKAPÉ GREY² OAK DEKAPÉ NATURAL² OAK DEKAPÉ POLAR² OAK DEKAPÉ SMITS²



OAK DEKAPÉ VOLCANIC² OAK EMERALD OAK GRIGIO SABBIA^{1 2} OAK LAVA GREY^{1 2} OAK LIMESTONE OAK MAKE UP WHITE OAK MARMOLINA GREY² OAK MUSEUM



OAK NATURAL OAK NATURALIZATO OAK NATURE OAK OLIVE¹ OAK PIAZZA DEI SIGNORI OAK PIETRA GREY² OAK QUERCIA ANTICA OAK SBIANCATO

NEW



OAK TRAVERTINO OAK SMOKED OAK SMOKED RED OAK STONE OAK VATICANO GREY² OAK VILLA

METALLIZZATI

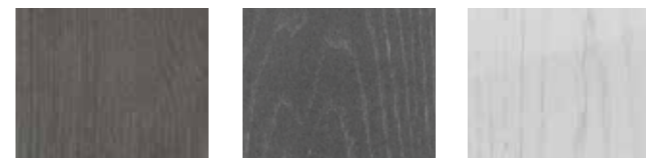

OAK FOUR SEASONS² OAK LAVA DARK OAK MCLAREN

TINTE UNITE



OAK CHERRY OAK EXTRA WHITE (matt/shine) OAK GRIGIO CEMENTO OAK GRIGIO PERLA OAK INDIGO OAK MENTHA OAK TORTORA OAK TURQUOISE

AMERICAN WALNUT

NEW



AMERICAN WALNUT ANTIQUE¹ AMERICAN WALNUT ASH AMERICAN WALNUT CAOBA-LUX AMERICAN WALNUT HONEY AMERICAN WALNUT LIGHT AMERICAN WALNUT NATURAL AMERICAN WALNUT SBIANCATO

EXOTIC

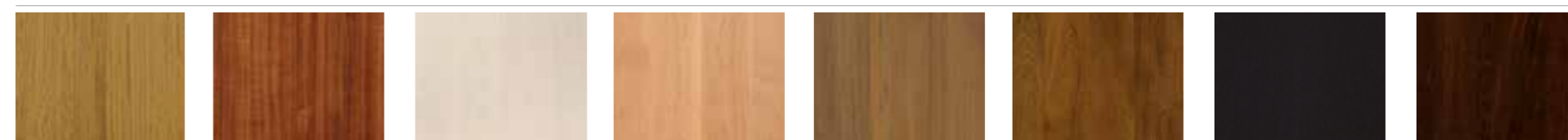

IROKO NATURAL JATOBA NATURAL MAPLE ICEBERG MAPLE NATURAL TEAK ASIA LIGHT TEAK ASIA NATURAL WENGE DARK WENGE NATURAL

1. Color & tone may vary from plank to plank due to reactive stain. **2.** Dekape color. **3.** Wood colors may not be exactly as illustrated due to variations during printing. Always refer to the color samples in store. **4.** All exotic species are subject to availability, especially for W+Listone/Tavole STP and Chevron series.

1. El color y tono puede variar de tabla a tabla debido al tinte reactivo. **2.** Color Dekape. **3.** Debido a las variaciones causadas por el proceso de impresión, los colores de la madera representados en este documento son sólo de referencia. Consulte siempre las muestras de color disponibles en las tiendas. **4.** Todas las especies exóticas están sujetas a disponibilidad, especialmente para las series W+Listone/Tavole STP y Chevron.

1. Color e tono possono variare da tavola a tavola a cause della vernice reattiva. **2.** Colore Dekape. **3.** A causa delle variazioni dovute al processo di stampa, i colori del legno rappresentati in questo documento sono solo indicativi. Si prega di visionare i campioni disponibili in negozio. **4.** Tutte le specie esotiche sono soggette a disponibilità, soprattutto per le serie W+Listone/Tavole STP e Chevron.

1. 由于反应性染色，不同地板的颜色和色调可能不同。 **2.** 表面颜色拉丝处理工艺。 **3.** 地板实物颜色可能与图片略有差别，请以实样为准。 **4.** 特殊木种视资源情况而定，尤其是直板和鱼骨拼系列。



FINISHES

STANDARD FINISH

CLASSIC



CLASSIC is a UV brushed finish, with “oil-effect”, micro-beveled on all four sides, open pore, resistant to moderate traffic. Gloss 5.

CLASSIC es un acabado UV cepillado, con “efecto aceite”, micro-biselado en los cuatro lados, poro abierto, resistente al tráfico moderado. Gloss 5.

CLASSIC è una finitura spazzolata UV, ad “effetto olio”, micro-bisellato sui quattro lati, poro aperto, resistente al traffico moderato. Gloss 5.

经典精选：
经典精选工艺是一种UV面漆处理，具有油效，四边微倒角，开放孔，适度耐磨。光泽度5度。

厚度是指加工前测量的，表层处理工艺，比如涂刷、手刮仿古或者锯齿纹理等处理后会影响最终整体厚度及倒角斜面。

TRADITIONAL



TRADITIONAL is a UV brushed finish, with “oil-effect”, micro-beveled on all four sides, open pore, with knots, resistant to moderate traffic. Gloss 5.

TRADITIONAL es un acabado UV cepillado, con “efecto aceite”, micro-biselado en los cuatro lados, poro abierto, con nudos, resistente al tráfico moderado. Gloss 5.

TRADITIONAL è una finitura spazzolata UV, ad “effetto olio”, micro-bisellato sui quattro lati, poro aperto, con nodi, resistente al traffico moderato. Gloss 5.

传统系列：
传统系列是一种UV面漆处理，具有油效，四边微倒角，开放孔，有结疤，适度耐磨。光泽度5度。

SPECIAL FINISH

TRAFFIC-BRUSHED



TRAFFIC-BRUSHED is a UV brushed finish, with semi-gloss effect, micro-beveled on all four sides, open pore, resistant to intense traffic. Gloss 15.

TRAFFIC-BRUSHED es un acabado UV cepillado, con efecto satinado, micro-biselado en los cuatro lados, poro abierto, resistente al tráfico intenso. Gloss 15.

TRAFFIC-BRUSHED è una finitura spazzolata UV, con effetto semilucido, micro-bisellato sui quattro lati, poro aperto, resistente al traffico intenso. Gloss 15.

耐磨涂刷
耐磨涂刷是一种UV面漆处理，具有半光亮的表面效果，四边微倒角，开放孔，极其耐磨。光泽度15度。

SHINE



SHINE is a UV brushed finish, with high gloss effect, micro-beveled on all four sides, open pore, resistant to moderate traffic. Gloss 85.

SHINE es un acabado UV cepillado, con efecto alto brillo, micro-biselado en los cuatro lados, poro abierto, resistente al tráfico moderado. Gloss 85.

SHINE è una finitura spazzolata UV, con effetto lucido, micro-bisellato sui quattro lati, poro aperto, resistente al traffico moderato. Gloss 85.

高光系列
高光系列是一种UV面漆处理，具有高光亮度的效果，四边微倒角，开放孔，适度耐磨。光泽度85度

LUX



LUX is a UV finish, with semi-gloss effect, micro-beveled on all four sides, close pore, smooth surface without brushing, resistant to moderate traffic. Gloss 25.

LUX es un acabado UV, con efecto satinado, micro-biselado en los cuatro lados, poro cerrado, superficie lisa sin cepillado, resistente al tráfico moderado. Gloss 25.

LUX è una finitura UV, con effetto semilucido, micro-bisellato sui quattro lati, poro chiuso, superficie liscia senza spazzolatura, resistente al traffico moderato. Gloss 25.

光亮系列
光亮系列是一种UV面漆处理，具有半光亮的表面效果，四边微倒角，封闭孔，表面光滑无涂刷工艺，适度耐磨。光泽度25度

HAND-SCRAPED



HAND-SCRAPED is a UV brushed finish with hand-scraped, with “oil-effect”, micro-beveled on all four sides prior to the finishing process, open pore, resistant to moderate traffic. Gloss 5.

HAND-SCRAPED es un acabado UV con cepillado a mano, con “efecto aceite”, micro-biselado en los cuatro lados antes del proceso de acabado, poro abierto, resistente al tráfico moderado. Gloss 5.

HAND-SCRAPED è una finitura spazzolata UV piallato a mano, ad “effetto olio”, micro-bisellato sui quattro lati prima della finitura, poro aperto, resistente al traffico moderato. Gloss 5.

手刮仿古
手刮仿古系列是一种UV漆，手刮拉丝涂刷工艺，具有油效，四边微倒角，开放孔，适度耐磨。光泽度5度。

CROSS-CUT



CROSS-CUT is a UV brushed finish with cross-cut saw, with “oil-effect”, micro-beveled on all four sides prior to the finishing process, open pore, resistant to moderate traffic. Gloss 5.

CROSS-CUT es un acabado UV cepillado con efecto de corte sierra transversal, con “efecto aceite”, micro-biselado en los cuatro lados antes del proceso de acabado, poro abierto, resistente al tráfico moderado. Gloss 5.

CROSS-CUT è una finitura spazzolata UV effeto taglio sega, ad “effetto olio”, micro-bisellato sui quattro lati prima della finitura, poro aperto, resistente al traffico moderato. Gloss 5.

锯齿拉丝
锯齿拉丝系列是一种UV漆，交叉锯齿纹理工艺，具有油效，四边微倒角，开放孔，适度耐磨。光泽度5度。

- p. 24 Wood+ Oak Brunello Dark
- p. 25 Wood+ Sizes
- p. 26 Wood+ Oak Natural
- p. 27 Wood+ Oak Natural
- p. 28 Wood+ Oak Villa
- p. 29 Wood+ Oak Marmolina Grey
- p. 30 Wood+ Oak Extra White / Oak Black Pearl
- p. 31 Wood+ Oak Sbiancato
- p. 32 Wood+ Oak Botanic
- p. 34 Wood+ Oak Anticato
- p. 35 Wood+ A. Walnut Natural
- p. 36 Wood+ Oak Anticato
- p. 37 Wood+ Oak Anticato / Oak Make Up White
- p. 38 Wood+ Oak Anticato / Oak Botanic
- p. 39 Wood+ Teak Asia Natural
- p. 40 Wood+ Oak Sbiancato
- p. 41 Wood+ Oak Sbiancato
- p. 42 Wood+ A. Walnut Natural
- p. 43 Wood+ A. Walnut Natural
- p. 44 Wood+ A. Walnut Natural
- p. 45 Wood+ Oak Emerald
- p. 46 Wood+ Oak Pietra Grey
- p. 48 Wood+ Oak Black Pearl
- p. 49 Wood+ Oak Black Pearl
- p. 50 Wood+ Oak DK Natural
- p. 51 Wood+ Oak Brunello / Oak Brunello Dark / Oak Sbiancato
- p. 52 Wood+ Oak Botanic
- p. 53 Wood+ Oak Extra White





Mounting Type-A

100% Made in Spain

SIZES

SIZES / FORMATOS / FORMATI / 尺寸及样式

WOOD+
MORE THAN WOOD

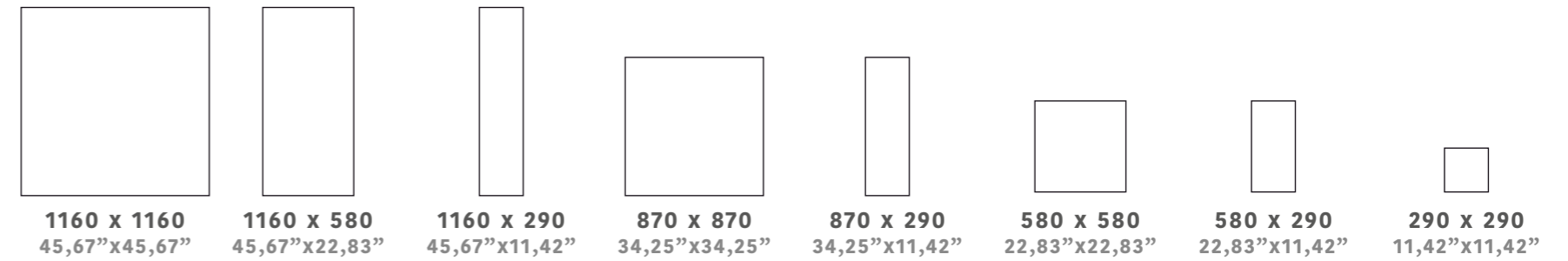

FINISH

FINISHES / ACABADOS / FINITURE / 成品

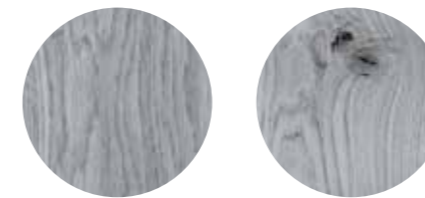

STANDARD FINISH

CLASSIC
CLASSIC is a UV brushed finish, with "oil-effect", micro-beveled on all four sides, open pore, resistant to moderate traffic. Gloss 5.

TRADITIONAL
TRADITIONAL is a UV brushed finish, with "oil-effect", micro-beveled on all four sides, open pore, with knots, resistant to moderate traffic. Gloss 5.

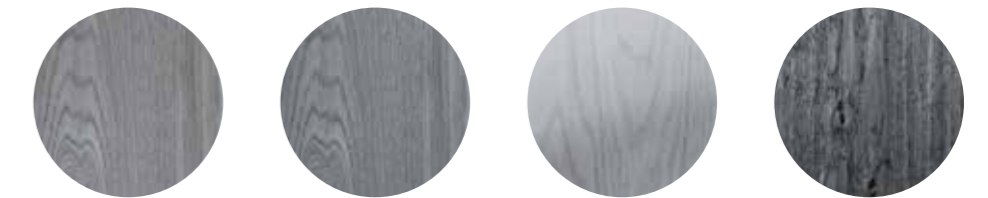

SPECIAL FINISH

TRAFFIC
TRAFFIC-BRUSHED is a UV brushed finish, with semi-gloss effect, micro-beveled on all four sides, open pore, resistant to intense traffic. Gloss 15.

SHINE
SHINE is a UV brushed finish, with high gloss effect, micro-beveled on all four sides, open pore, resistant to moderate traffic. Gloss 85.

LUX
LUX is a UV finish, with semi-gloss effect, micro-beveled on all four sides, close pore, smooth surface without brushing, resistant to moderate traffic. Gloss 25.

HAND-SCRAPED
HAND-SCRAPED is a UV brushed finish with hand-scraped, with "oil-effect", micro-beveled on all four sides prior to the finishing process, open pore, resistant to moderate traffic. Gloss 5.

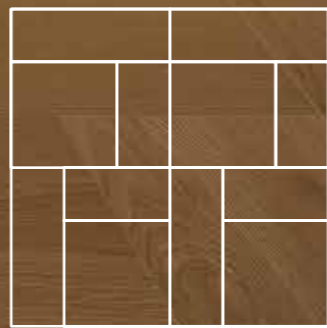
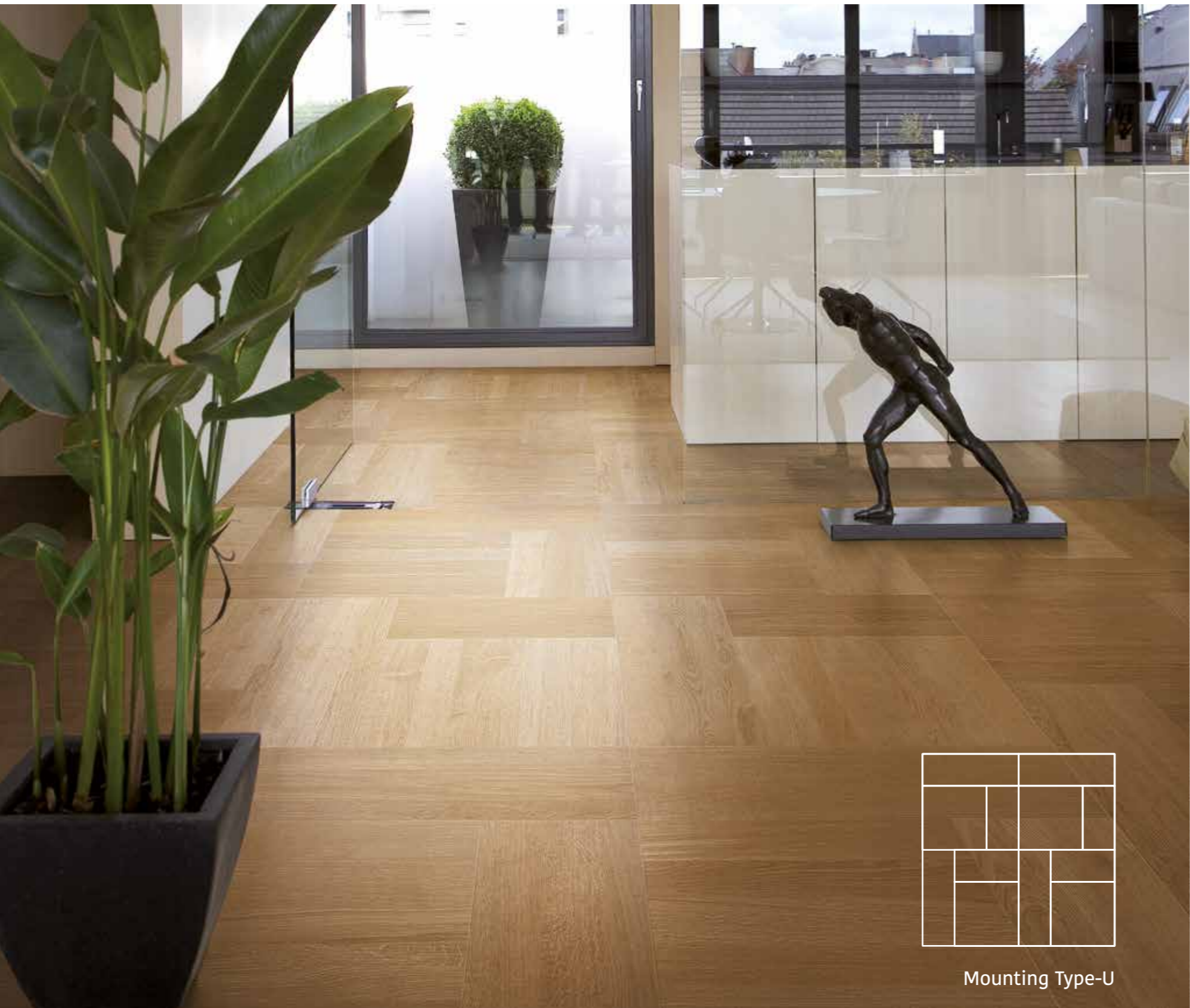

Mounting Type-U

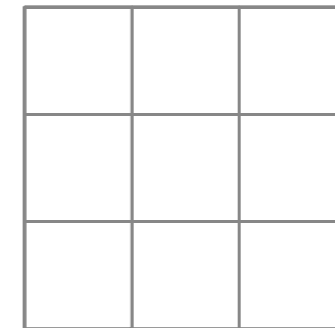

Mounting Type-A





Mounting Type-0

580x580 - 580x290 Oak Villa



Mounting Type-A

580x580 Oak Marmolina Grey



Mounting Type-A

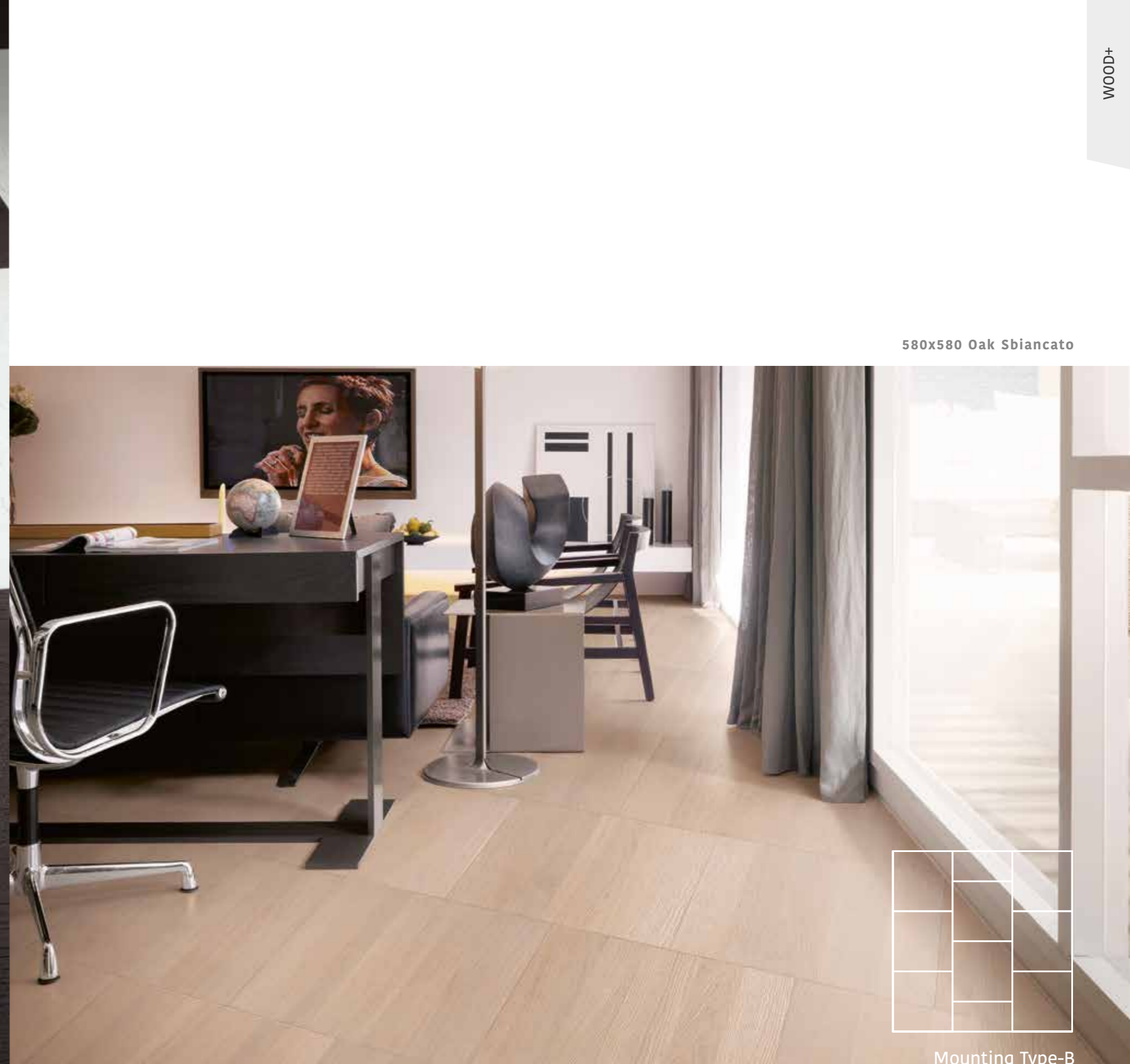

580x580 Oak Sbiancato

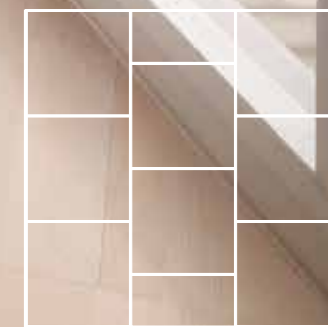

Mounting Type-B



580x580 Oak Botanic



Mounting Type-A

580x580 Oak Anticato



Mounting Type-A

1160x1160 A. Walnut Natural

1160x1160 Oak Anticato



Mounting Type-A

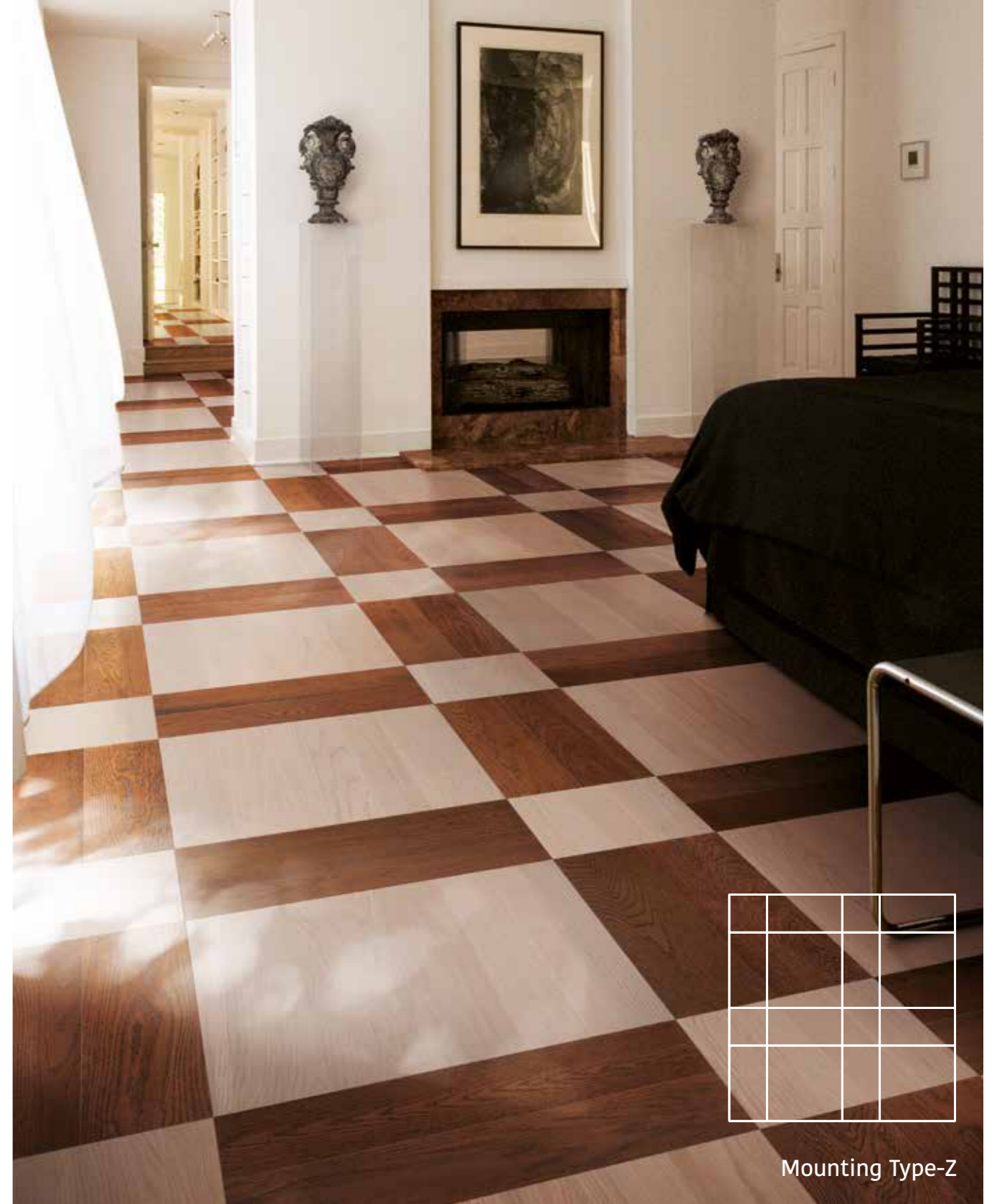

Mounting Type-Z

580x145 Oak Anticato - 580x580 - 290x290 Oak Make Up White

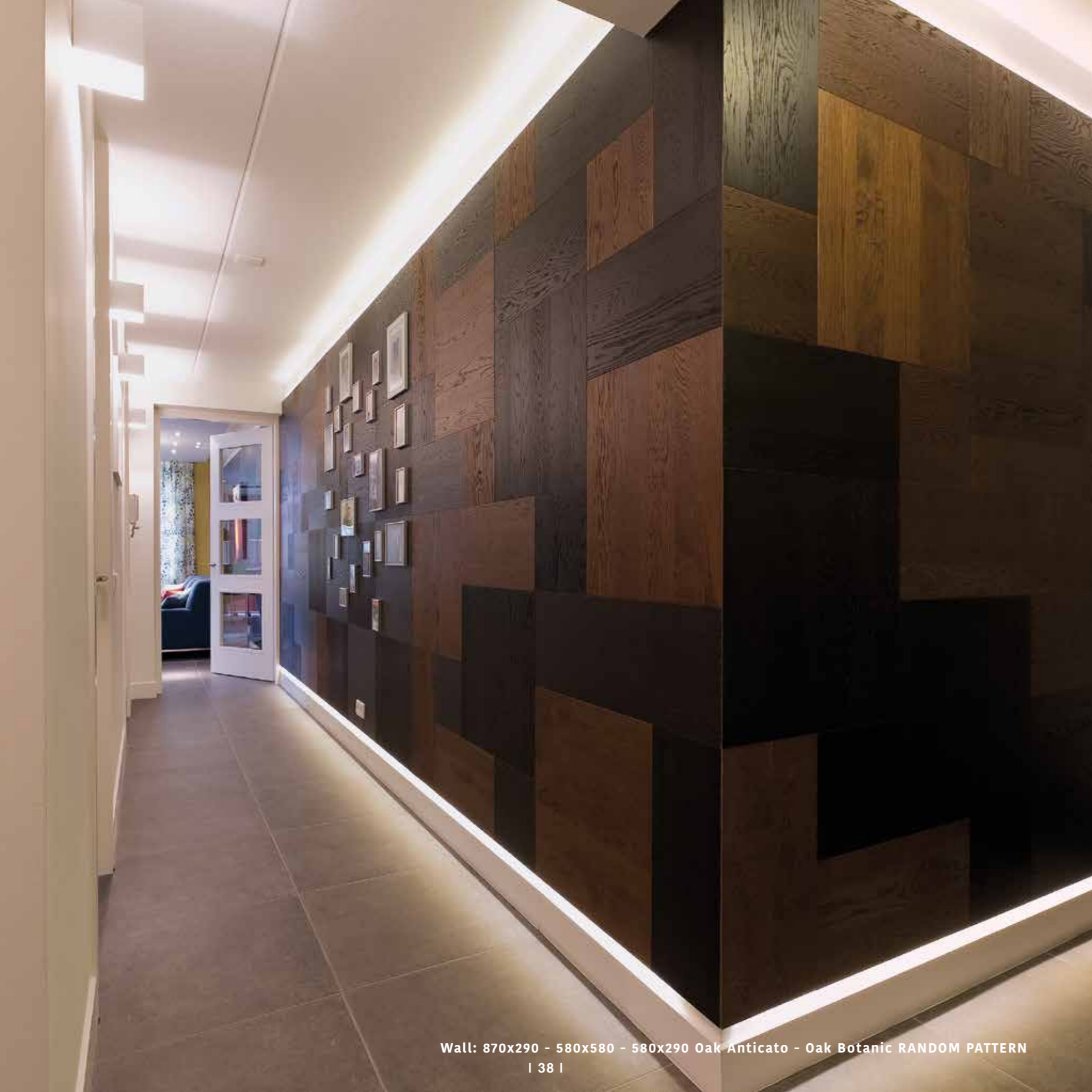

Wall: 870x290 - 580x580 - 580x290 Oak Anticato - Oak Botanic RANDOM PATTERN

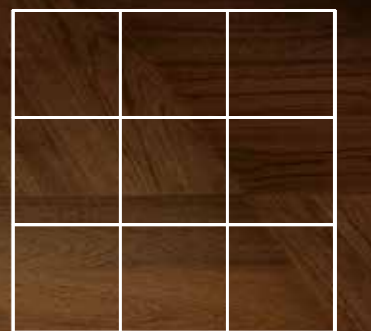

Mounting Type-A

580x580 Teak Asia Natural

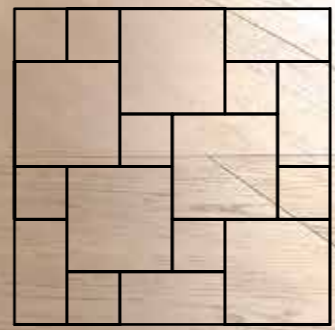

Mounting Type-P

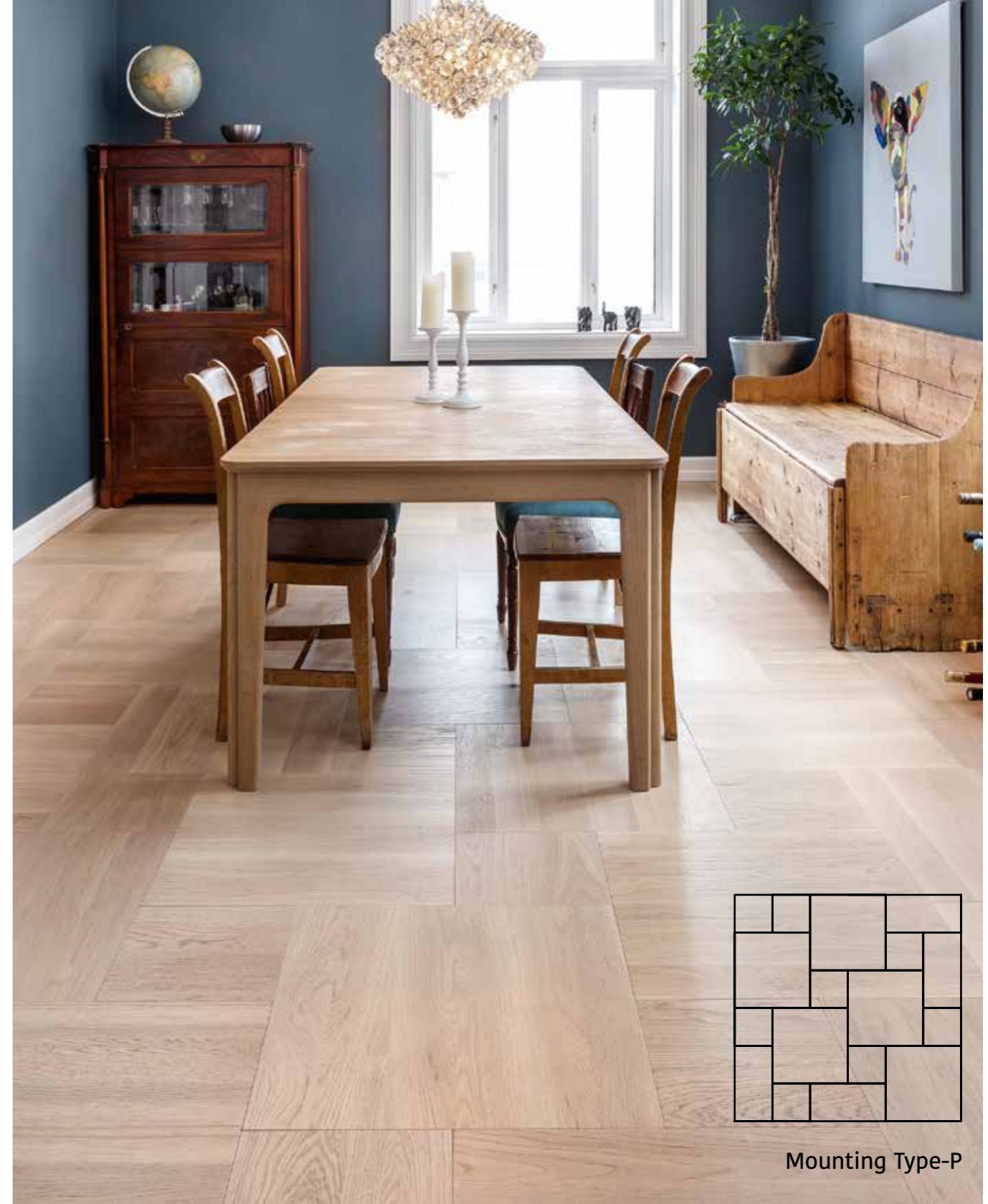

Mounting Type-P

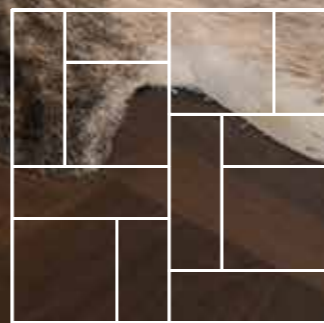

Mounting Type-U

870x290 - 580x580 - 580x290 A. Walnut Natural

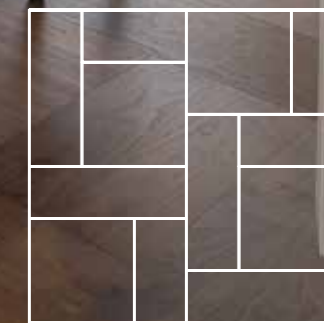
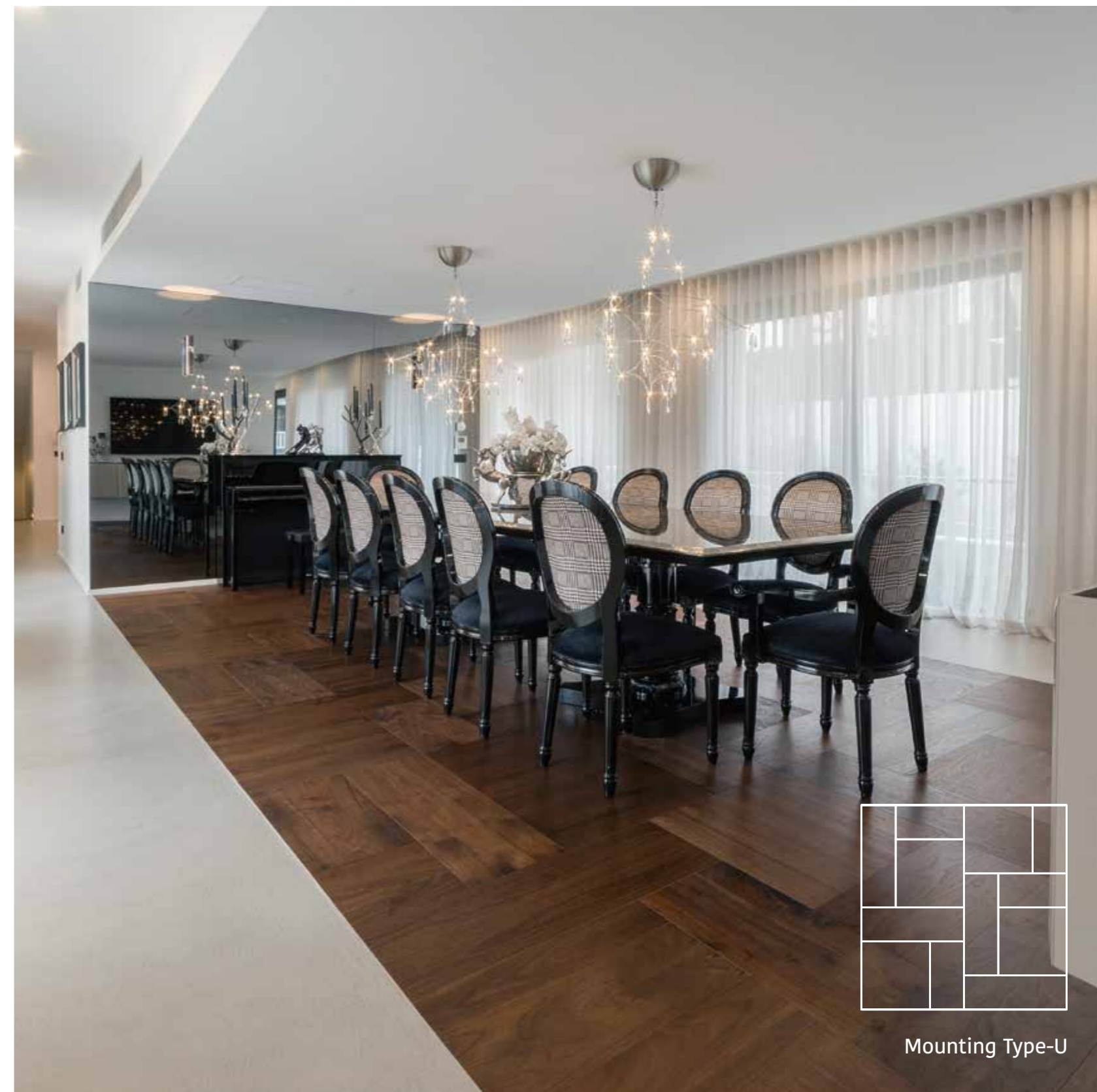

Mounting Type-U

870x290 - 580x580 - 580x290 A. Walnut Natural

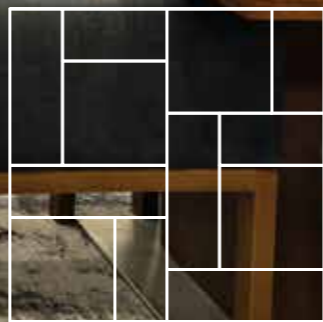

Mounting Type-U

870x290 - 580x580 - 580x290 A. Walnut Natural

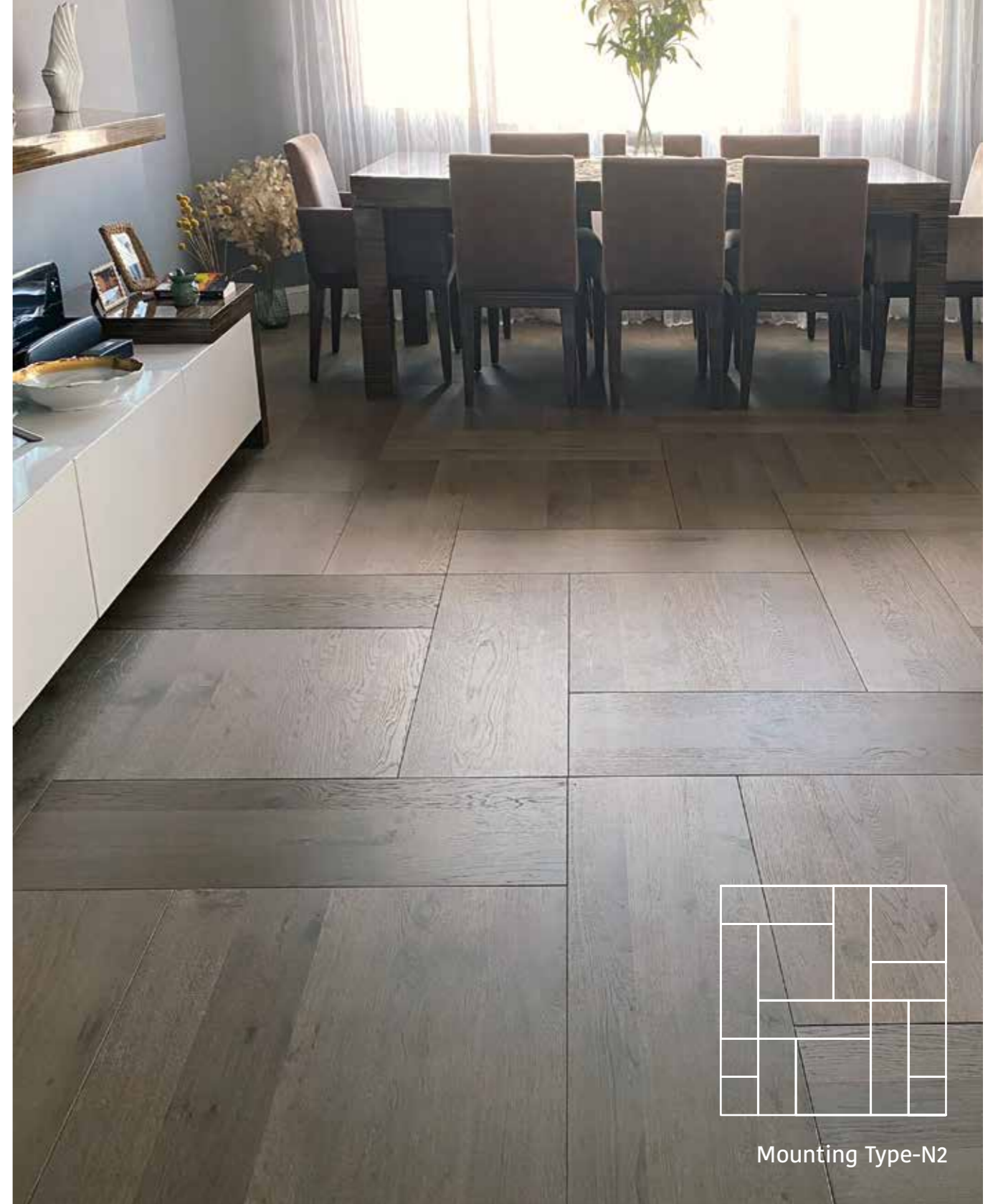

Mounting Type-N2

870x290 - 580x580 Oak Emerald



Mounting Type-U



870x290 - 580x580 - 580x290 Oak Pietra Grey

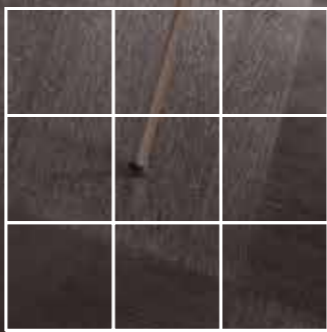

Mounting Type-A



Mounting Type-H

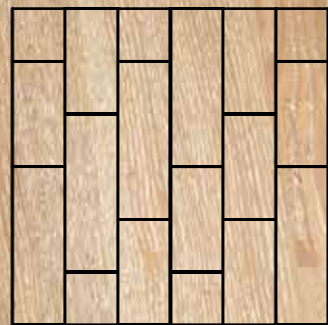

Mounting Type-M

870x290 - 580x290 Oak DK Natural



Mounting Type-H

870x290 Oak Brunello - Oak Brunello Dark - Oak Sbiancato



Mounting Type-B

1160x580 Oak Botanic

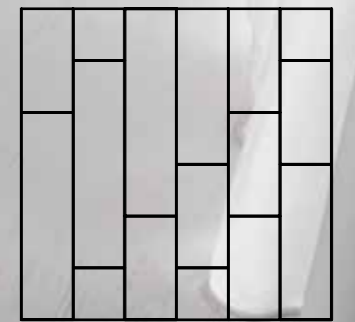

Mounting Type-AD

1160x290 - 870x290 - 580x290 Oak Extra White

- p. 56 W+Listone & Tavole STP Sizes
- p. 58 W+Listone Oak Smoked (Traditional)
- p. 59 Tavole STP Oak Pietra Grey
- p. 60 Tavole STP Oak Marmolina Grey
- p. 61 W+Listone Oak Villa (Cross - cut)
- p. 62 W+Listone Oak DK Polar
- p. 63 W+Listone Oak Piazza dei Signori
- p. 64 Tavole STP Oak Cognac
- p. 66 W+Listone A. Walnut Light
- p. 67 Tavole STP A. Walnut Ash
- p. 68 Tavole STP A. Walnut Natural
- p. 69 W+Listone Herringbone Oak Grigio Sabbia



W⁺ LISTONE[®]
Tavole[®] STP

W + LISTONE

SIZES

SIZES / FORMATOS / FORMATI / 尺寸及样式



with LockSTP system, for floating installation

¹Regular orders to be in 2 MIXED LENGTHS of 2030-1740 MM. ²MIXED LENGTHS of 2030-1740-1450-1160 MM., available under request.

*Herringbone engineering, always 145 MM. width, available under request & subject to an extra cost.

con sistema LockSTP, para instalación flotante

¹Pedidos ordinarios con 2 LARGOS MIXTOS de 2030-1740 MM. ²LARGOS MIXTOS ALEATORIOS de 2030-1740-1450-1160 MM., disponibles bajo pedido.

*Mecanizado Herringbone, siempre ancho de 145 MM., disponible bajo pedido y sujeto a un cargo extra.

con sistema LockSTP, per installazione flottante

¹Ordini standard in 2 LUNGHEZZE MISTE di 2030-1740 MM. ²LUNGHEZZE MISTE (RANDOM) di 2030-1740-1450-1160 MM., disponibile su richiesta.

*Sistema herringbone, sempre in larghezza di 145 MM., disponibile su richiesta e soggetto a un costo adizionale.

使用LockSTP安装系统，可无胶悬浮安装。

¹常规直板订单，地板长度为两种规格，2030毫米和1740毫米 ²混合不等长，长度为2030-1740-1450-1160 毫米

*可做人字拼，宽度为145毫米，可定制，需加收额外费用

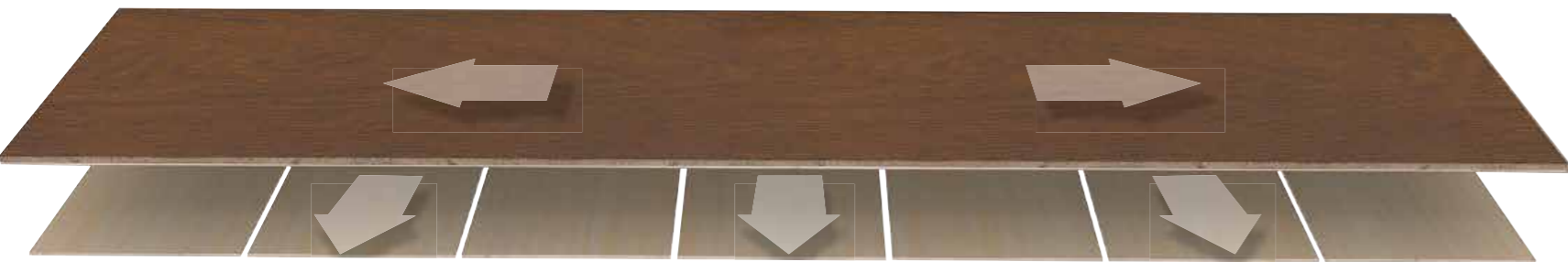
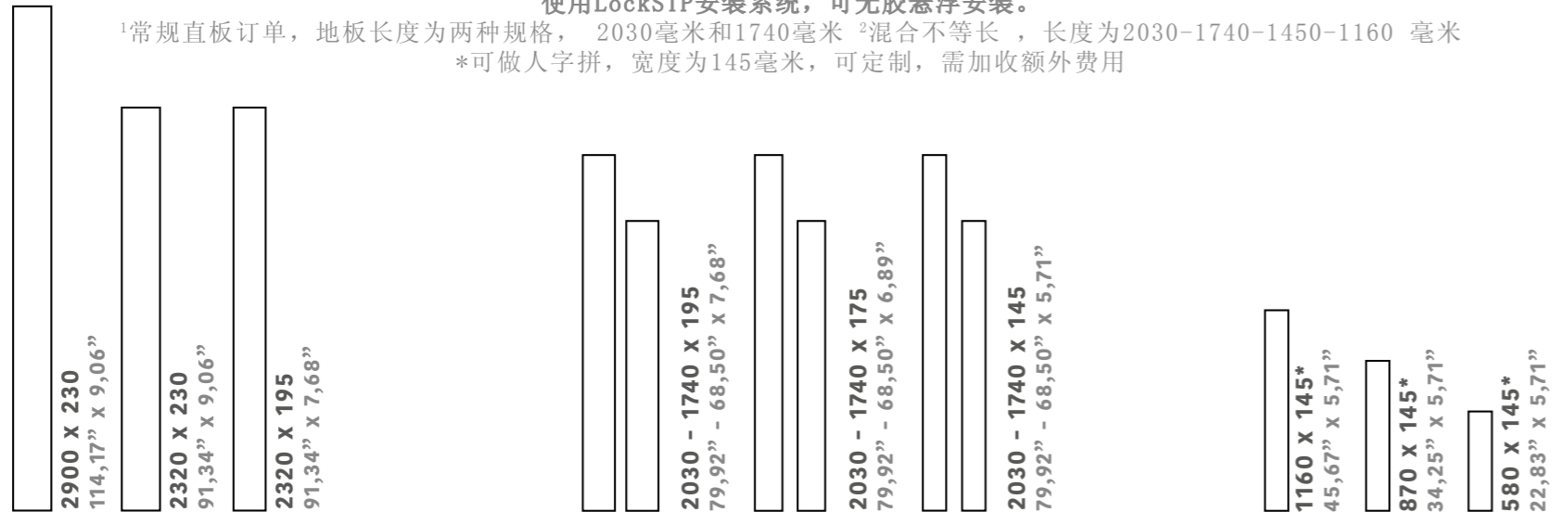

Precision, flexibility & stability
 Precisión, flexibilidad & estabilidad
 Precisione, flessibilità e stabilità
 精度，灵活性及稳定性

Tavole STP

with traditional T&G system, for glue down installation

¹Regular orders to be in 2 MIXED LENGTHS of 2030-1740 MM. ²MIXED LENGTHS of 2030-1740-1450-1160 MM., available under request.

*Herringbone engineering, always 145 MM. width, available under request & subject to an extra cost.

con sistema tradicional T&G, para instalación encolada

¹Pedidos ordinarios con 2 LARGOS MIXTOS de 2030-1740 MM. ²LARGOS MIXTOS ALEATORIOS de 2030-1740-1450-1160 MM., disponibles bajo pedido.

*Mecanizado Herringbone, siempre ancho de 145 MM., disponible bajo pedido y sujeto a un cargo extra.

con sistema tradizionale T&G, per installazione incollata

¹Ordini standard in 2 LUNGHEZZE MISTE di 2030-1740 MM. ²LUNGHEZZE MISTE (RANDOM) di 2030-1740-1450-1160 MM., disponibile su richiesta.

*Sistema herringbone, sempre in larghezza di 145 MM., disponibile su richiesta e soggetto a un costo adizionale.

使用传统安装方式，胶水安装

¹常规直板订单，地板长度为两种规格，2030毫米和1740毫米 ²混合不等长，长度为2030-1740-1450-1160 毫米

*可做人字拼，宽度为145毫米，可定制，需加收额外费用

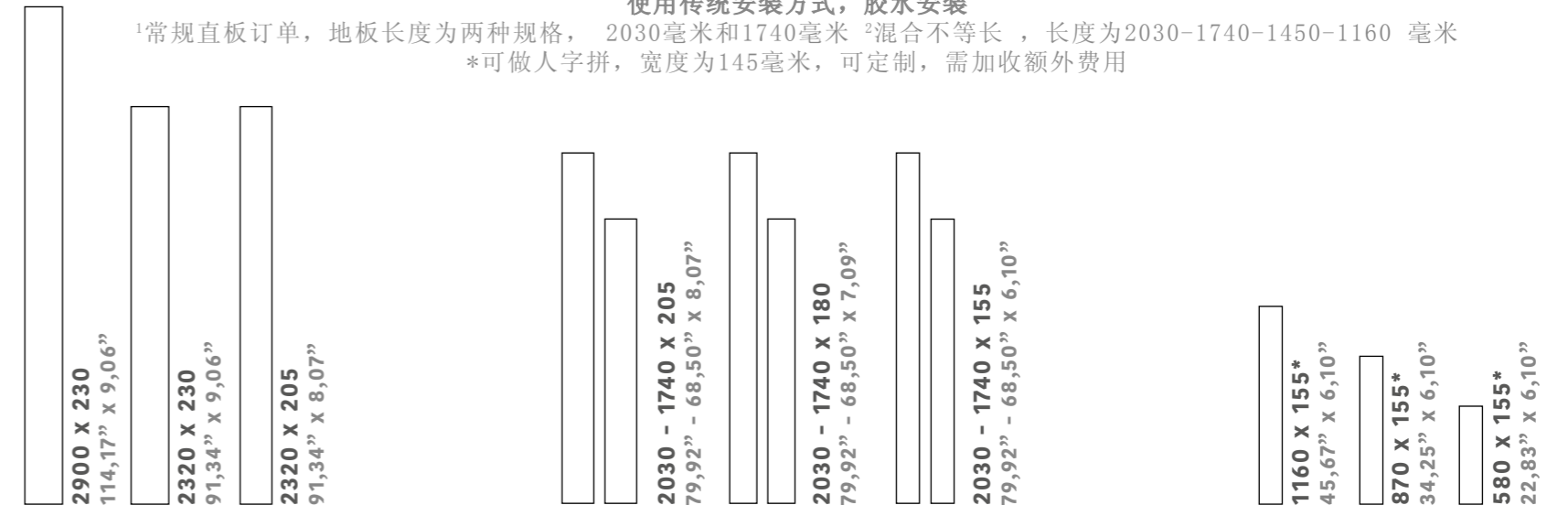

FINISH

FINISHES / ACABADOS / FINITURE / 成品



STANDARD FINISH

CLASSIC
 CLASSIC is a UV brushed finish, with "oil-effect", micro-beveled on all four sides, open pore, resistant to moderate traffic. Gloss 5.



TRADITIONAL
 TRADITIONAL is a UV brushed finish, with "oil-effect", micro-beveled on all four sides, open pore, with knots, resistant to moderate traffic. Gloss 5.



TRAFFIC
 TRAFFIC-BRUSHED is a UV brushed finish, with semi-gloss effect, micro-beveled on all four sides, open pore, resistant to intense traffic. Gloss 15.

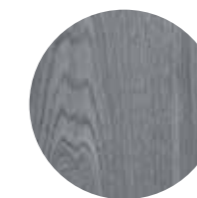

SHINE
 SHINE is a UV brushed finish, with high gloss effect, micro-beveled on all four sides, open pore, resistant to moderate traffic. Gloss 85.



LUX
 LUX is a UV finish, with semi-gloss effect, micro-beveled on all four sides, close pore, smooth surface without brushing, resistant to moderate traffic. Gloss 25.

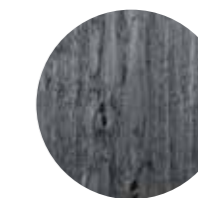

HAND-SCRAPED
 HAND-SCRAPED is a UV brushed finish with hand-scraped, with "oil-effect", micro-beveled on all four sides prior to the finishing process, open pore, resistant to moderate traffic. Gloss 5.



CROSS-CUT
 CROSS-CUT is a UV brushed finish with cross-cut saw, with "oil-effect", micro-beveled on all four sides prior to the finishing process, open pore, resistant to moderate traffic. Gloss 5.

2030x195 Oak Smoked (Traditional)

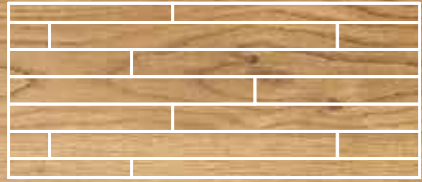

2030x180 Oak Pietra Grey



2030x180 Oak Marmolina Grey



2030x195 Oak Villa (Cross - cut)

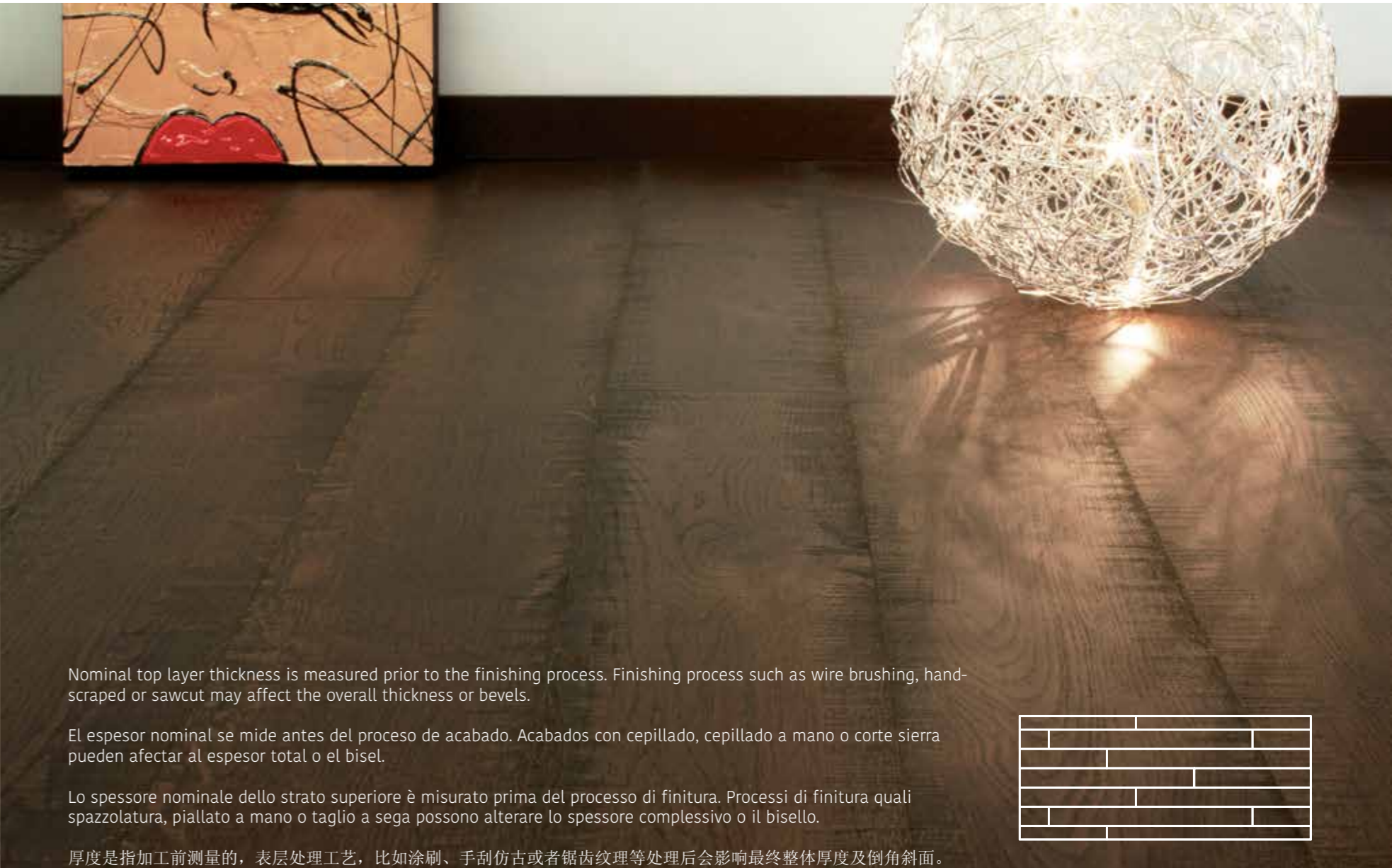

Nominal top layer thickness is measured prior to the finishing process. Finishing process such as wire brushing, hand-scraped or sawcut may affect the overall thickness or bevels.

El espesor nominal se mide antes del proceso de acabado. Acabados con cepillado, cepillado a mano o corte sierra pueden afectar al espesor total o el bisel.

Lo spessore nominale dello strato superiore è misurato prima del processo di finitura. Processi di finitura quali spazzolatura, piattato a mano o taglio a sega possono alterare lo spessore complessivo o il bisello.

厚度是指加工前测量的，表层处理工艺，比如涂刷、手刮仿古或者锯齿纹理等处理后会影最终整体厚度及倒角斜面。

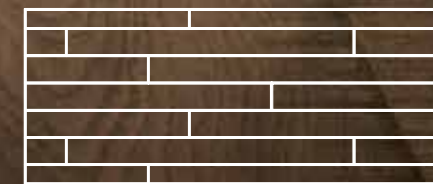

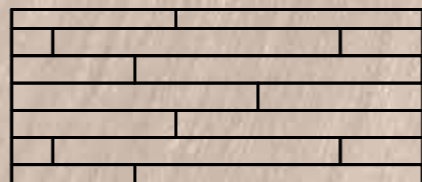

2030x195 Oak DK Polar



2030x195 Oak Piazza dei Signori



2030x155 Oak Cognac



2030x145 A. Walnut Light

2030x155 A. Walnut Ash



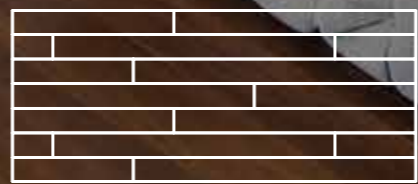
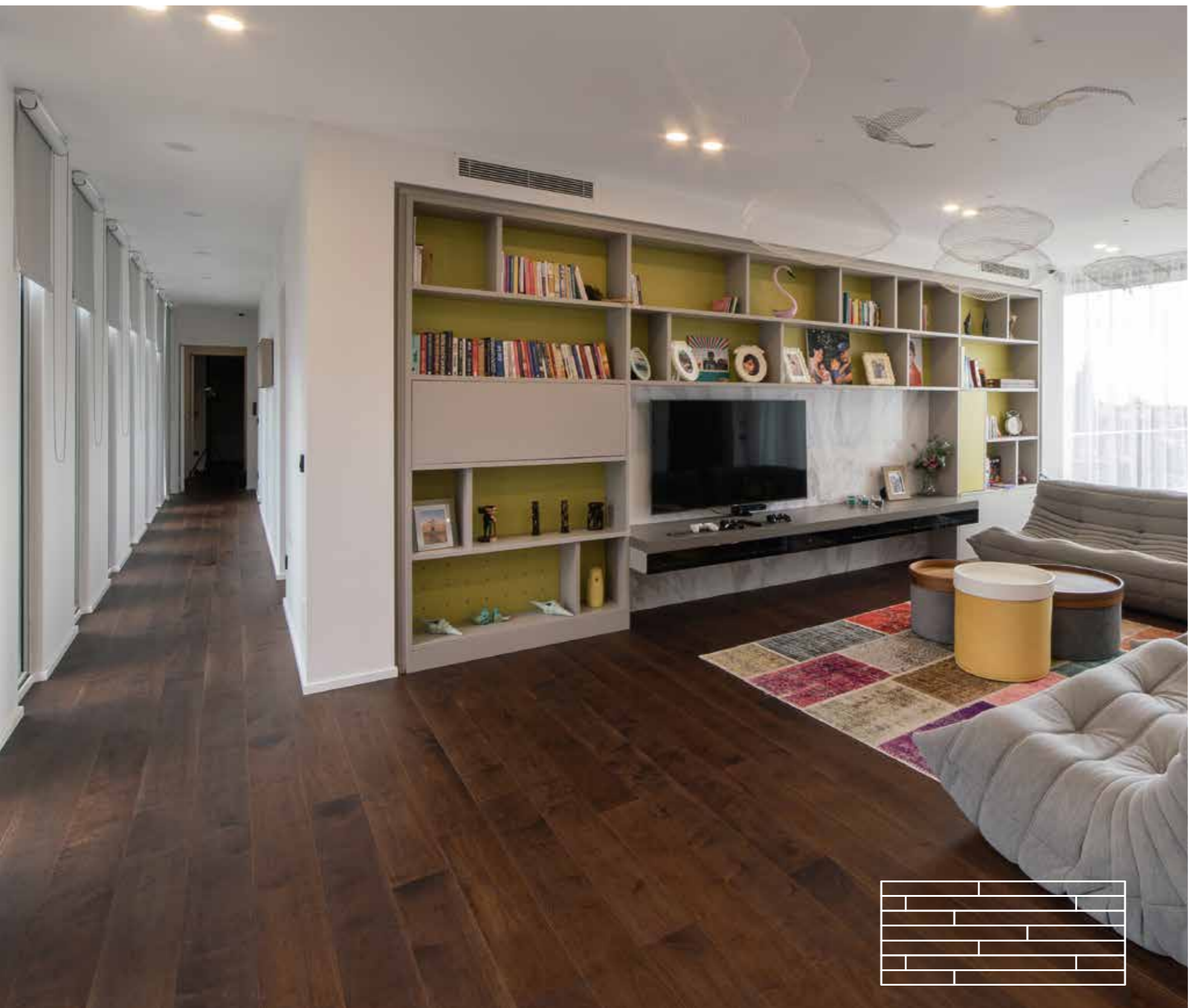

2030x180 A. Walnut Natural



Herringbone 580x145 Oak Grigio Sabbia

- p. 72** Chevron A. Walnut Natural
- p. 73** Chevron Sizes
- p. 74** Chevron A. Walnut Light / Oak Sbiancato
- p. 75** Chevron A. Walnut Ash
- p. 76** Chevron Oak Smoked (Traditional)
- p. 77** Chevron Oak DK Polar
- p. 78** Chevron Oak Make Up White / Oak Ash / Oak Limestone / Oak Stone
- p. 80** Chevron A. Walnut Antique
- p. 82** Chevron Wenge Natural
- p. 83** Chevron Wenge Natural / Oak Natural
- p. 84** Chevron Oak Limestone
- p. 85** Chevron Oak Natural

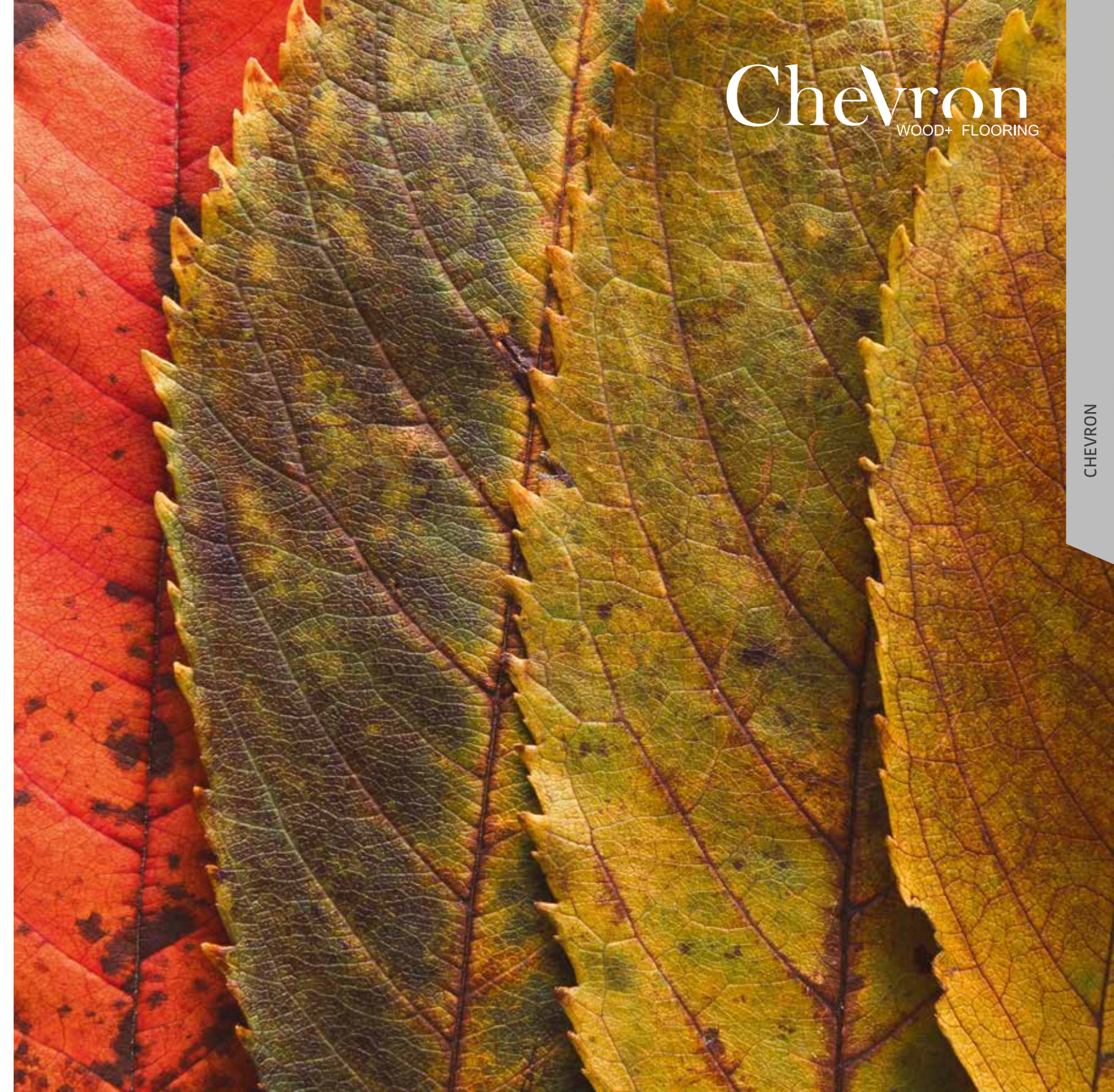



100% Made in Spain

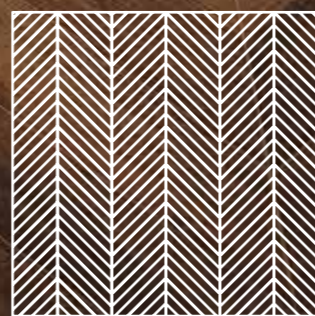

CHEVRON Mounting Type-A

Chevron 3 strip 580x205 A. Walnut Natural

SIZES

SIZES / FORMATOS / FORMATI / 尺寸及样式

Chevron

WOOD+ FLOORING

3 STRIP - 68,4 WIDTH

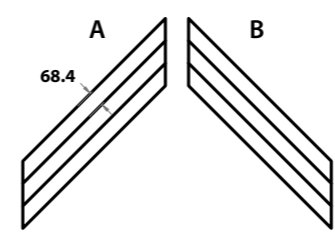

870x205
34,25"x8,07"

2 STRIP - 102,5 WIDTH

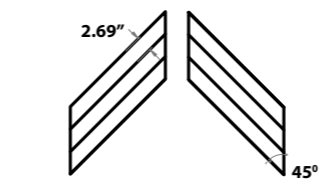
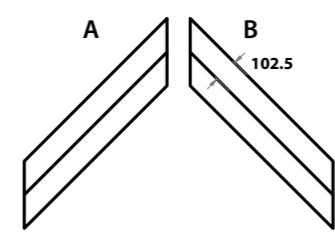

580x205
22,83"x8,07"

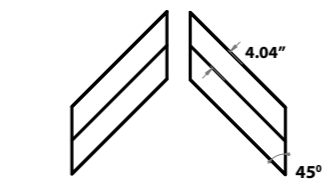

1 STRIP - 205,1 WIDTH

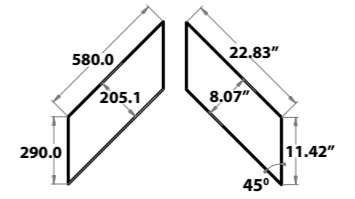
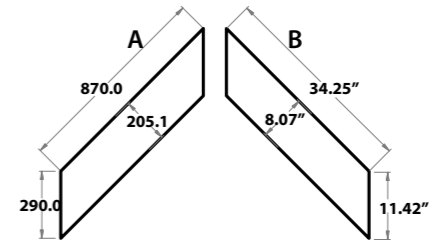

1 STRIP- 145,0 WIDTH

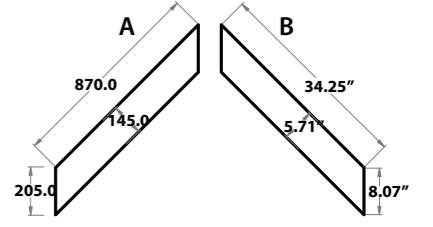

870x145
34,25"x5,71"

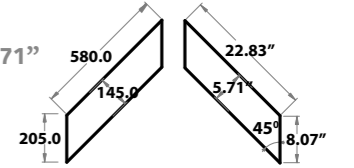

580x145
22,83"x5,71"

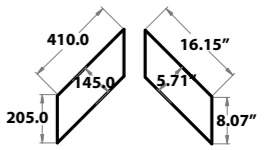

410x145
16,15"x5,71"

FINISH

FINISHES / ACABADOS / FINITURE / 成品



STANDARD FINISH

CLASSIC
CLASSIC is a UV brushed finish, with "oil-effect", micro-beveled on all four sides, open pore, resistant to moderate traffic. Gloss 5.

TRADITIONAL
TRADITIONAL is a UV brushed finish, with "oil-effect", micro-beveled on all four sides, open pore, with knots, resistant to moderate traffic. Gloss 5.

SPECIAL FINISH

TRAFFIC
TRAFFIC-BRUSHED is a UV brushed finish, with semi-gloss effect, micro-beveled on all four sides, open pore, resistant to intense traffic. Gloss 15.

SHINE
SHINE is a UV brushed finish, with high gloss effect, micro-beveled on all four sides, open pore, resistant to moderate traffic. Gloss 85.

HAND-SCRAPED
HAND-SCRAPED is a UV brushed finish with hand-scraped, with "oil-effect", micro-beveled on all four sides prior to the finishing process, open pore, resistant to moderate traffic. Gloss 5.



CHEVRON Mounting Type-K

Chevron 3 strip 870x205 A. Walnut Light - 580x205 Oak Sbiancato
| 74 |



CHEVRON Mounting Type-A

Chevron 1 strip 580x145 A. Walnut Ash

| 75 |

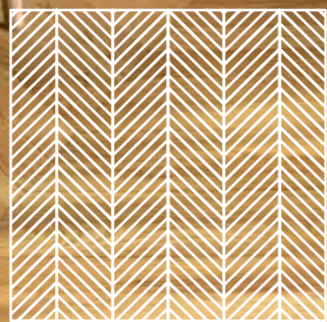

CHEVRON Mounting Type-A

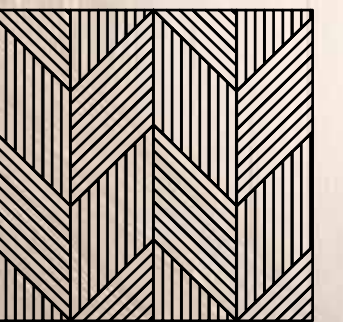

CHEVRON Mounting Type-L



Chevron 2 strip 580x205 Oak Make Up White - Oak Ash - Oak Limestone - Oak Stone



CHEVRON Mounting Type-A



Chevron 1 strip 410x145 A. Walnut Antique

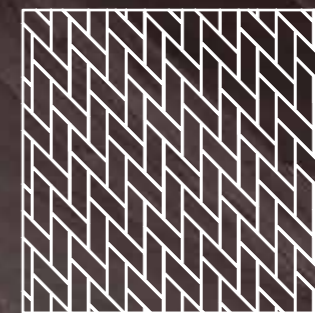

CHEVRON Mounting Type-K

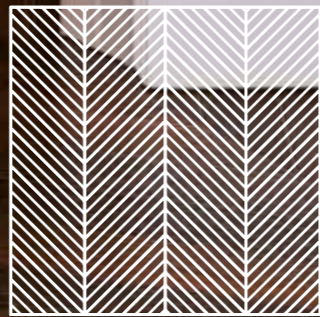
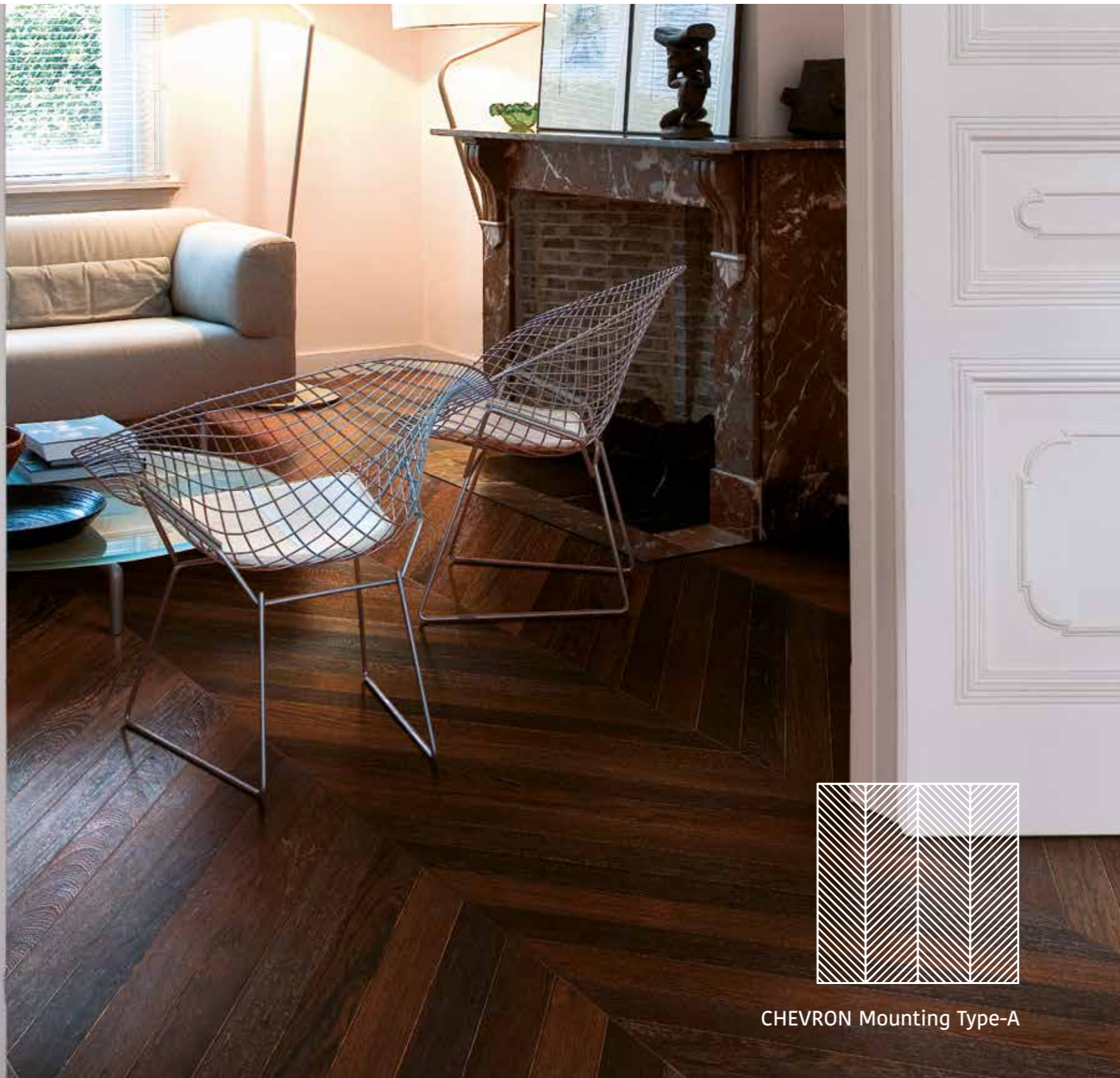

CHEVRON Mounting Type-A

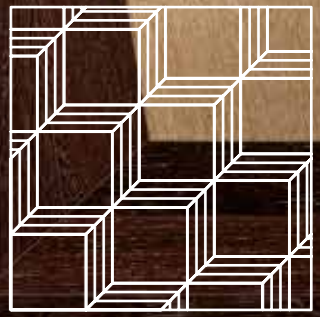
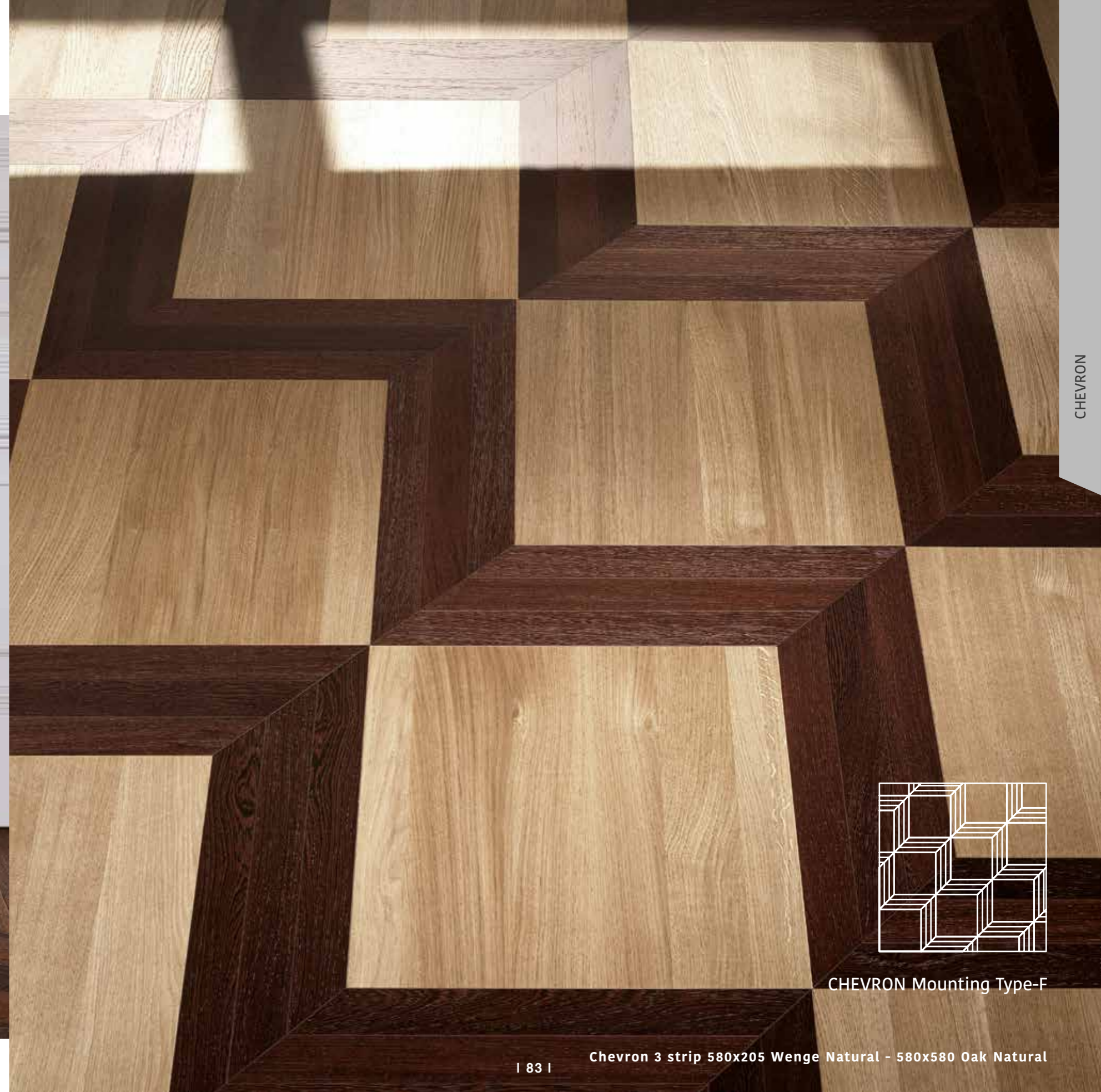

CHEVRON Mounting Type-F

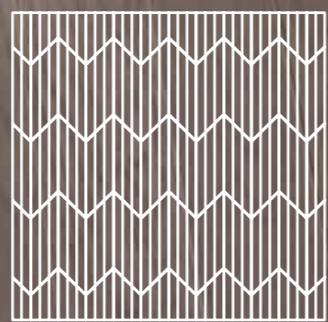

CHEVRON Mounting Type-C

Chevron 3 strip 580x205 Oak Limestone

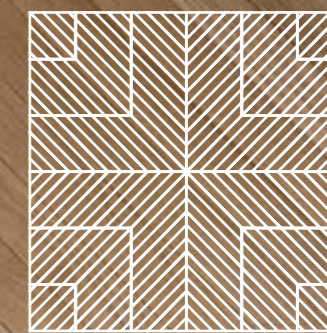

CHEVRON Mounting Type-E

Chevron 3 strip 580x205 Oak Natural

- p. 88 W+Design Sizes
- p. 92 W+Design Braid Oak Aged
- p. 94 W+Design Braid Oak Brunello
- p. 95 W+Design Diamond Oak Extra White / Oak Black Pearl / Oak Limestone
- p. 96 Wood+ Oak Make Up White / W+Design Trapezium A. Walnut Natural / A. Walnut Sbiancato
- p. 97 W+Design Trapezium Oak Olive
- p. 98 W+Design Hexagon Oak Black Pearl
- p. 99 W+Design Hexagon Oak Black Pearl
- p. 100 W+Design Hexagon Oak Extra White / Oak Cherry / Oak Piazza dei Signori / Oak Natural
- p. 101 W+Design Hexagon Oak Limestone / Oak Natural
- p. 102 W+Design Squama Oak Ash / Oak Stone
- p. 103 W+Design Squama Oak Limestone
- p. 104 W+Design Morisco A. Walnut Natural
- p. 105 W+Design 45° A. Walnut Natural
- p. 106 W+Design Looping 8 Oak Naturalizzato
- p. 107 W+Design Looping 8 A. Walnut Light
- p. 108 W+Design Dados Walnut Natural
- p. 109 W+Design Dados Oak Natural
- p. 110 W+Design Dados Oak Natural
- p. 111 W+Design Silhouette Oak Natural / A. Walnut Natural
- p. 112 W+Design Trencadis A. Walnut Sbiancato
- p. 113 W+Design Rhombus Oak Stone (Cross - cut)
- p. 114 W+Design Spike Oak Ash / Oak Limestone
- p. 115 W+Design Arrow Oak Lava Dark
- p. 116 Wood+ Oak Natural / W+Design Multiline Bicolor Maple Natural - A. Walnut Natural
- p. 117 W+Design Multiline A. Walnut Natural
- p. 118 W+Design Multiline Infinity Line
- p. 119 W+Design Multiline Infinity Line



SIZES

SIZES / FORMATOS / FORMATI / 尺寸及样式



TRAPEZIUM 870 870x145 34,25"x5,71"	TRAPEZIUM 580 580x145 22,83"x5,71"	TRIANGLE 580x580 22,83"x22,83"	SILHOUETTE 580x783 22,83"x30,83"	DIAMOND 502x290 19,77"x11,42"	MORISCO 290x290 11,42"x11,42"	SQUAMA 290x290 11,42"x11,42"

TRENCADIS 1160x580 45,67"x22,83"	RHOMBUS 1160x290 45,67"x11,42"	MULTINE 870x290 34,25"x11,42"	MULTILINE 580x580 22,83"x22,83"	45° 580x580 22,83"x22,83"	DADOS 290x290 11,42"x11,42"

HEXAGON 580 580x502 22,83"x19,76"	HEXAGON 290 290x251 11,42"x9,88"	BRAID A / B 580x145 22,83"x5,71" BRAID C 615x410 24,21"x16,14"

MULTI-RIGATO
2030x195
79,92"x7,68"

LOOPING 8
2030x230
79,92"x9,06"

FINISH*

FINISHES / ACABADOS / FINITURE / 成品

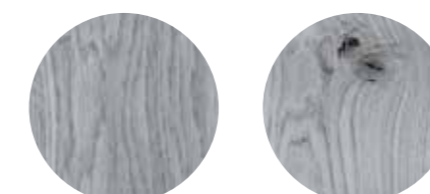

STANDARD FINISH

CLASSIC
CLASSIC is a UV brushed finish, with "oil-effect", micro-beveled on all four sides, open pore, resistant to moderate traffic. Gloss 5.

TRADITIONAL
TRADITIONAL is a UV brushed finish, with "oil-effect", micro-beveled on all four sides, open pore, with knots, resistant to moderate traffic. Gloss 5.

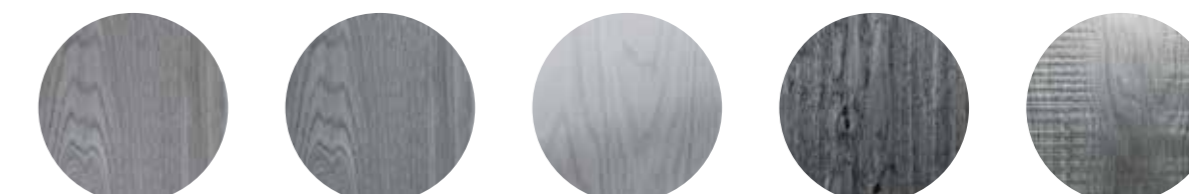

SPECIAL FINISH

TRAFFIC
TRAFFIC-BRUSHED is a UV brushed finish, with semi-gloss effect, micro-beveled on all four sides, open pore, resistant to intense traffic. Gloss 15.

SHINE
SHINE is a UV brushed finish, with high gloss effect, micro-beveled on all four sides, open pore, resistant to moderate traffic. Gloss 85.

LUX
LUX is a UV finish, with semi-gloss effect, micro-beveled on all four sides, close pore, smooth surface without brushing, resistant to moderate traffic. Gloss 25.

HAND-SCRAPED
HAND-SCRAPED is a UV brushed finish with hand-scraped, with "oil-effect", micro-beveled on all four sides prior to the finishing process, open pore, resistant to moderate traffic. Gloss 5.

CROSS-CUT
CROSS-CUT is a UV brushed finish with cross-cut saw, with "oil-effect", micro-beveled on all four sides prior to the finishing process, open pore, resistant to moderate traffic. Gloss 5.

* Check availability of finishes according to format. Consultar disponibilidad de acabados según formato. Verifica la disponibilità delle finiture in base al formato. 根据规格确认表面处理工艺的可用性

MULTILINE

BICOLOR MAPLE NATURAL A. WALNUT NATURAL

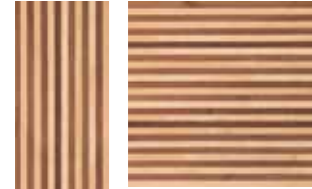

580x580
22,83"x22,83"

870x290
34,25"x11,42"

A. WALNUT NATURAL



580x580
22,83"x22,83"

870x290
34,25"x11,42"

INFINITY LINE



580x580
22,83"x22,83"

870x290
34,25"x11,42"

45°



580x580
22,83"x22,83"

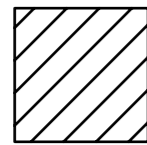

*45° grain direction
*Dirección de malla 45°
*Direzioe della venatura 45°
*木纹纹理呈45度斜纹

DADOS



OAK NATURAL
290x290
11,42"x11,42"

*End Grain cutting, only for glue down installation
*Corte a testa, solo para instalación encolada
*Legno di testa, solo per posa incollata
*切割工艺制成形似马赛克，只能用胶水安装



A. WALNUT NATURAL
290x290
11,42"x11,42"

BRAID

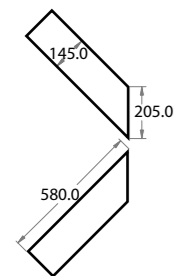

BRAID A / B
580x145
22,83"x5,71"

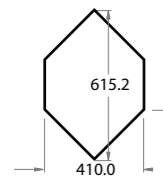

BRAID C
615x410
24,21"x16,14"

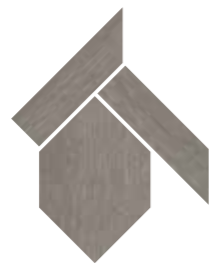

TRENCADIS

*3 different designs (composed of 5 different wooden portions each), 2 variations with opposite grain direction for each design, results in 6 completely different pieces.
*3 diseños diferentes (compuestos por 5 porciones de madera cada uno), 2 variaciones con dirección de malla opuesta para cada diseño, dan como resultado 6 piezas completamente diferentes.
* 3 disegni diversi (composti da 5 diverse porzioni di legno ciascuno), 2 varianti con direzione della venatura opposta per ogni disegno, si traduce in 6 pezzi completamente diversi
*3种不同设计（每个设计由5个模块组成），两种纵横变换方式，搭配垂直和水平相互交错木纹纹理，使得一组高迪型产品可以变换出6种不同的形态。



TRENCADIS
1160x580
45,67"x22,83"

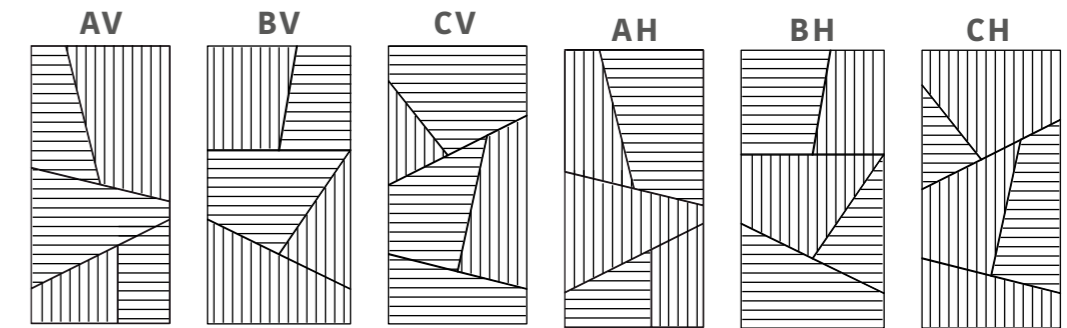

LOOPING 8



*8 different pieces. Maxi-bevel available under request.
*8 piezas diferentes. Maxi-bisel disponible bajo pedido.
*8 pezzi diversi. Maxi-bisello disponibile su richiesta.
*一组产品由8片组成。如需可定制成大倒角。

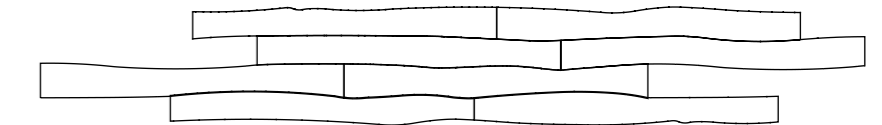

LOOPING 8
2030x230
79,92"x9,06"

MULTI-RIGATO

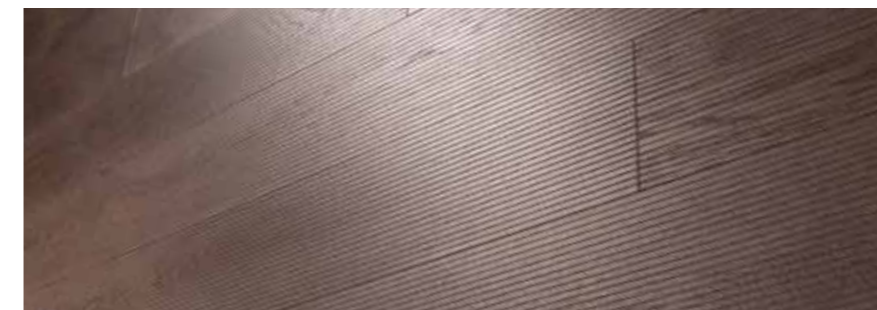

MULTI-RIGATO* OAK ANTIQUE LAVA 2030X195

*Just for wall coverings
*Solo para revestimientos de pared
*Solo per rivestimenti pareti
*仅可用于墙面装饰

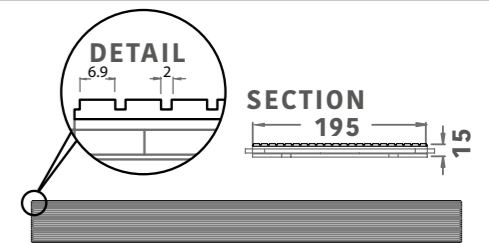

MULTI-RIGATO
2030x195
79,92"x7,68"



Braid 615x410 - 580x145 Oak Aged

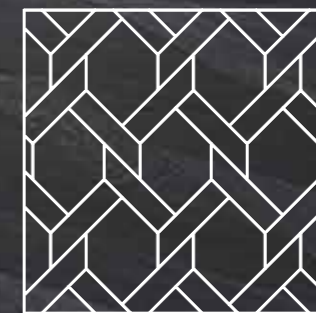

Mounting Type-BRAID



Mounting Type-BRAID

Braid 615x410 - 580x145 Oak Brunello

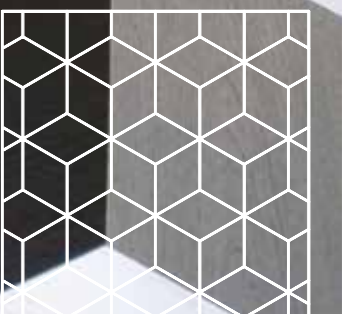

Mounting Type-DIAMOND

Diamond 502x290 Oak Extra White - Oak Black Pearl - Oak Limestone

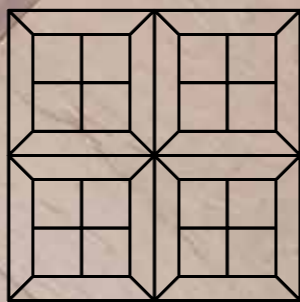

TRAPEZIUM Mounting Type-D

290x290 Oak Make Up White - Trapezium 870x145 A. Walnut Natural - A. Walnut Sbiancato



Trapezium 580x145 Oak Olive

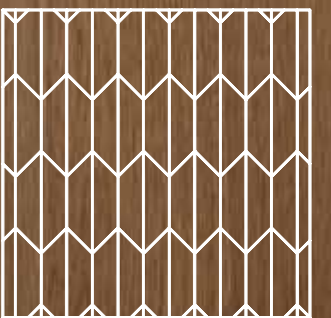

TRAPEZIUM Mounting Type-A

Color & tone may vary from plank to plank due to reactive stain.
El color y tono puede variar de tabla a tabla debido al tinte reactivo.
Color e tono possono variare da tavola a tavola a cause della vernice reattiva.
由于反应性染色，不同地板的颜色和色调可能不同。

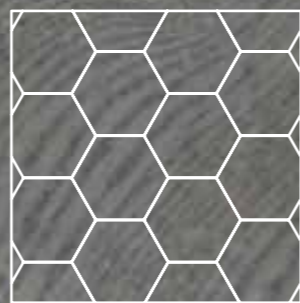

Mounting Type-HEXAGON

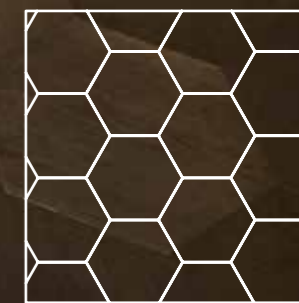
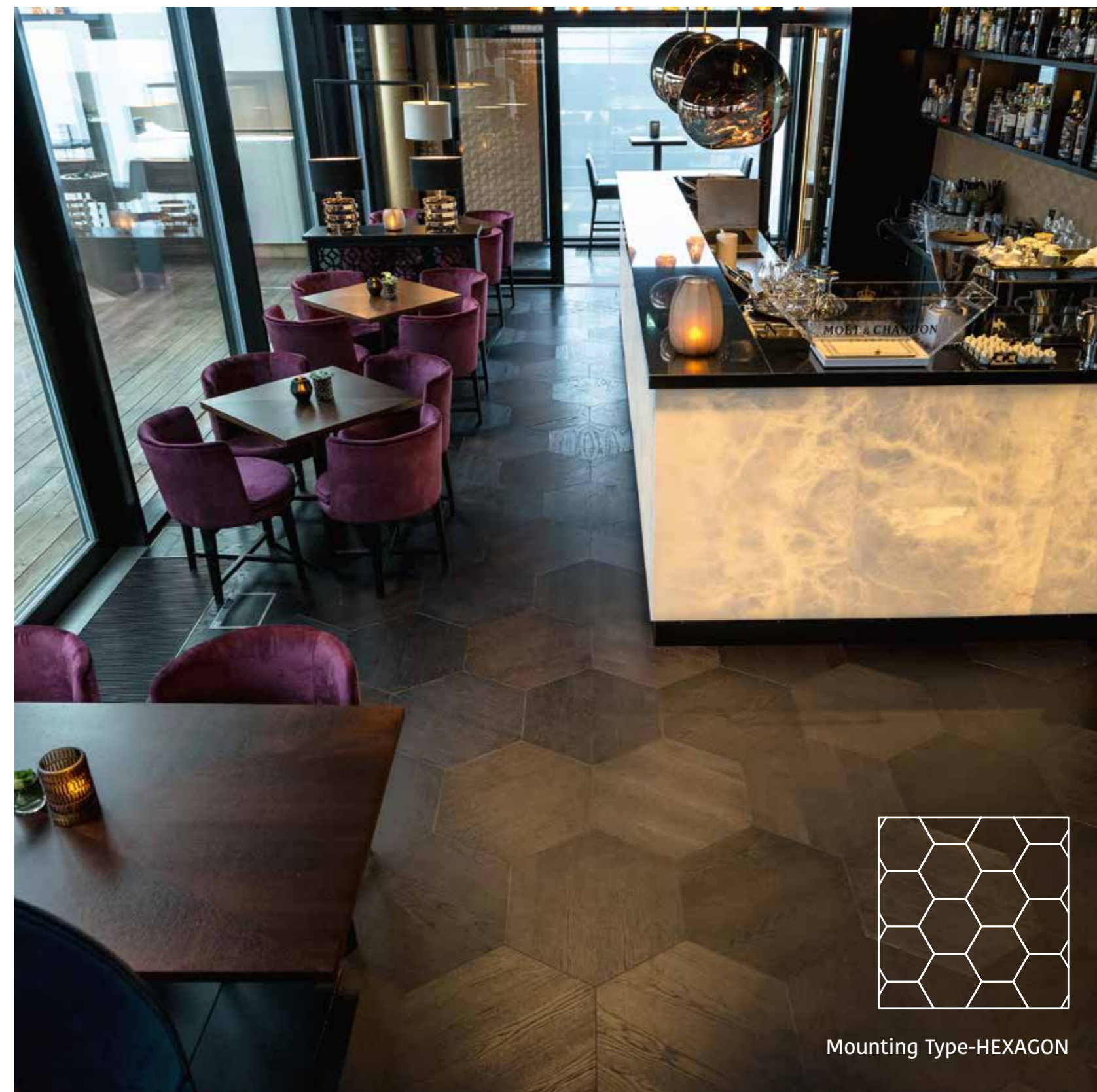

Mounting Type-HEXAGON

Hexagon 290x251 Oak Extra White - Oak Cherry - Oak Piazza dei Signori - Oak Natural



Mounting Type-HEXAGON

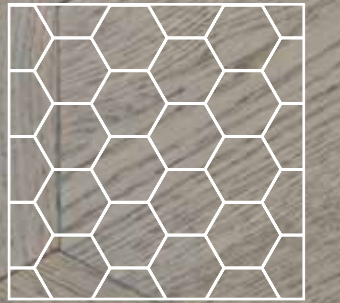

Mounting Type-HEXAGON

Hexagon 290x251 Oak Limestone - Oak Natural



Mounting Type-SQUAMA



Mounting Type-SQUAMA
Squama 290x290 Oak Limestone

Mounting type just valid for glue down installation
Esquema de montaje sólo válido para instalación encolada
Tipo di montaggio valido solo per posa incollata
装配类型只用胶合安装

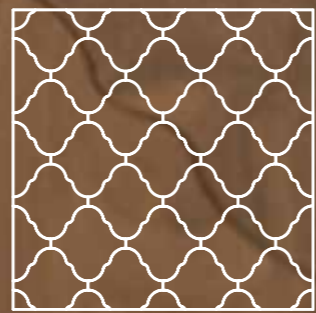

Mounting Type-MORISCO

Morisco 290x290 A. Walnut Natural

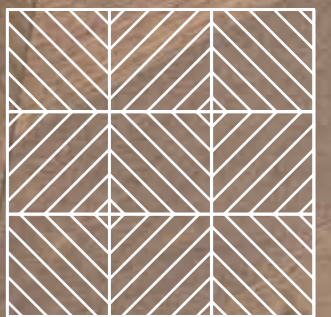

Mounting Type-45G

45° 580x580 A. Walnut Natural

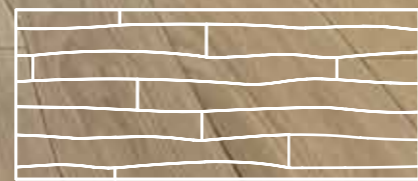

Mounting Type-LOOPING 8

Looping 8 2030x230 Oak Naturalizzato

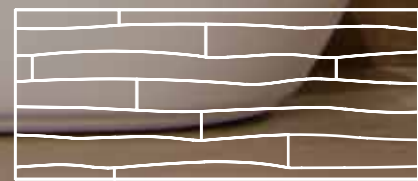

Mounting Type-LOOPING 8

Looping 8 2030x230 A. Walnut Light

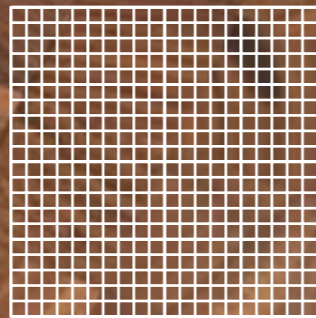

Mounting Type-DADOS

Dados 290x290 A. Walnut Natural

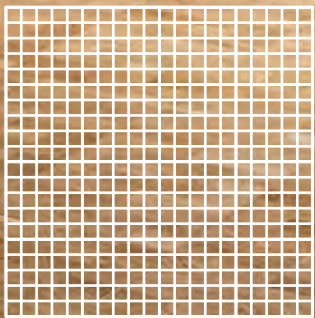

Mounting Type-DADOS

Dados 290x290 Oak Natural

Dados 290x290 Oak Natural

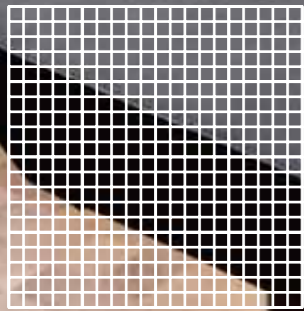

Mounting Type-DADOS

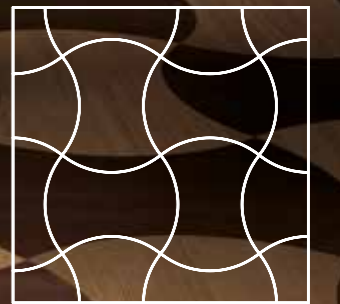

Mounting Type-SILHOUETTE

Silhouette 783x580 Oak Natural - A. Walnut Natural



TRENCADIS Mounting Type-A

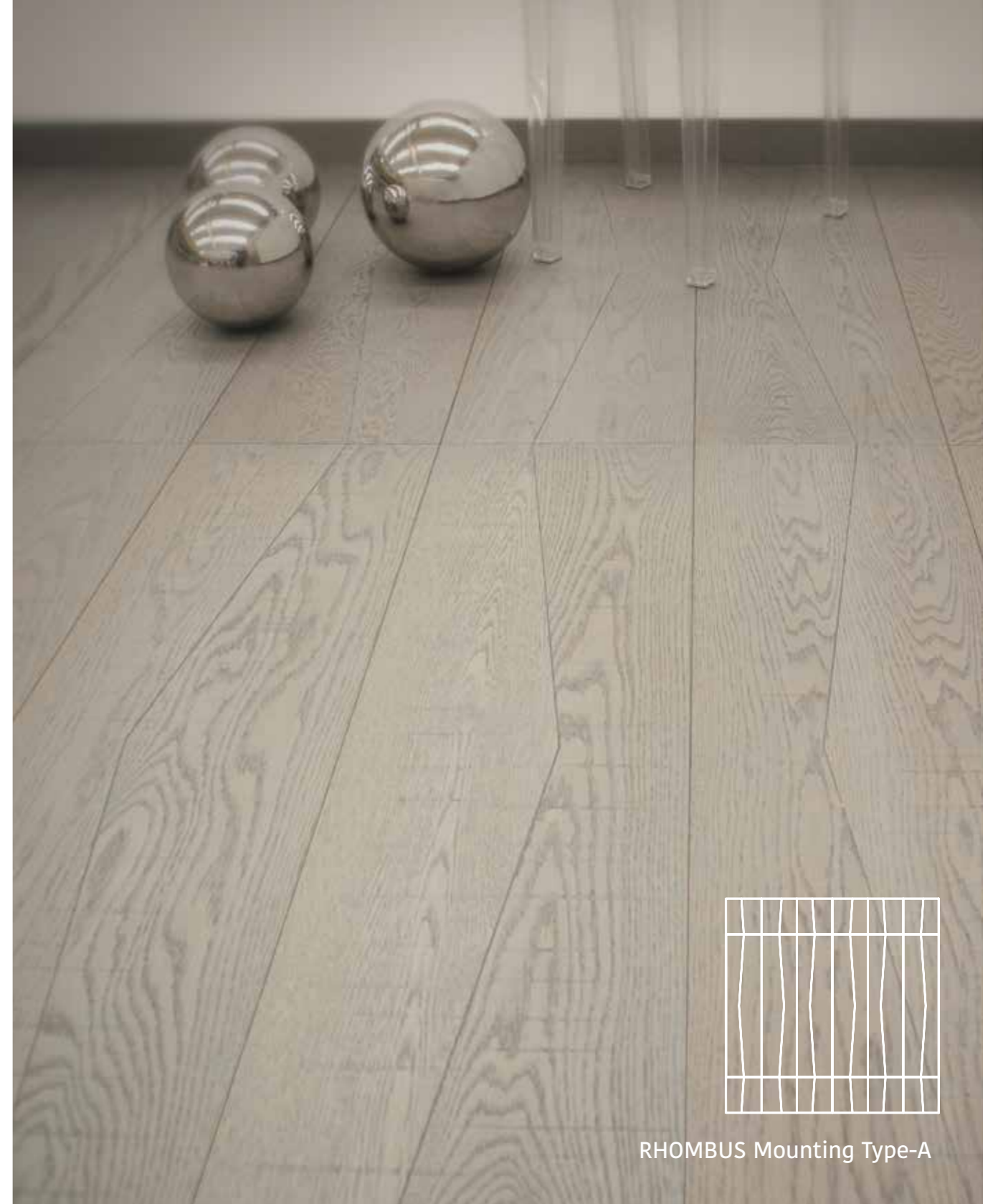

RHOMBUS Mounting Type-A

Rhombus 1160x290 Oak Stone (Cross - cut)

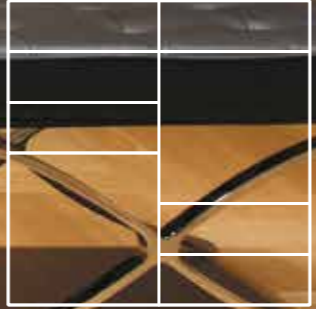

Mounting Type-S

Floor: 870x870 Oak Natural - Wall: 870x870 Oak Natural - Multiline 870x290 Bicolor Maple Natural - A. Walnut Natural
| 116 |

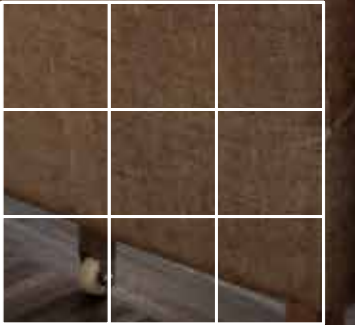

Mounting Type-A

Multiline 580x580 A. Walnut Natural

| 117 |

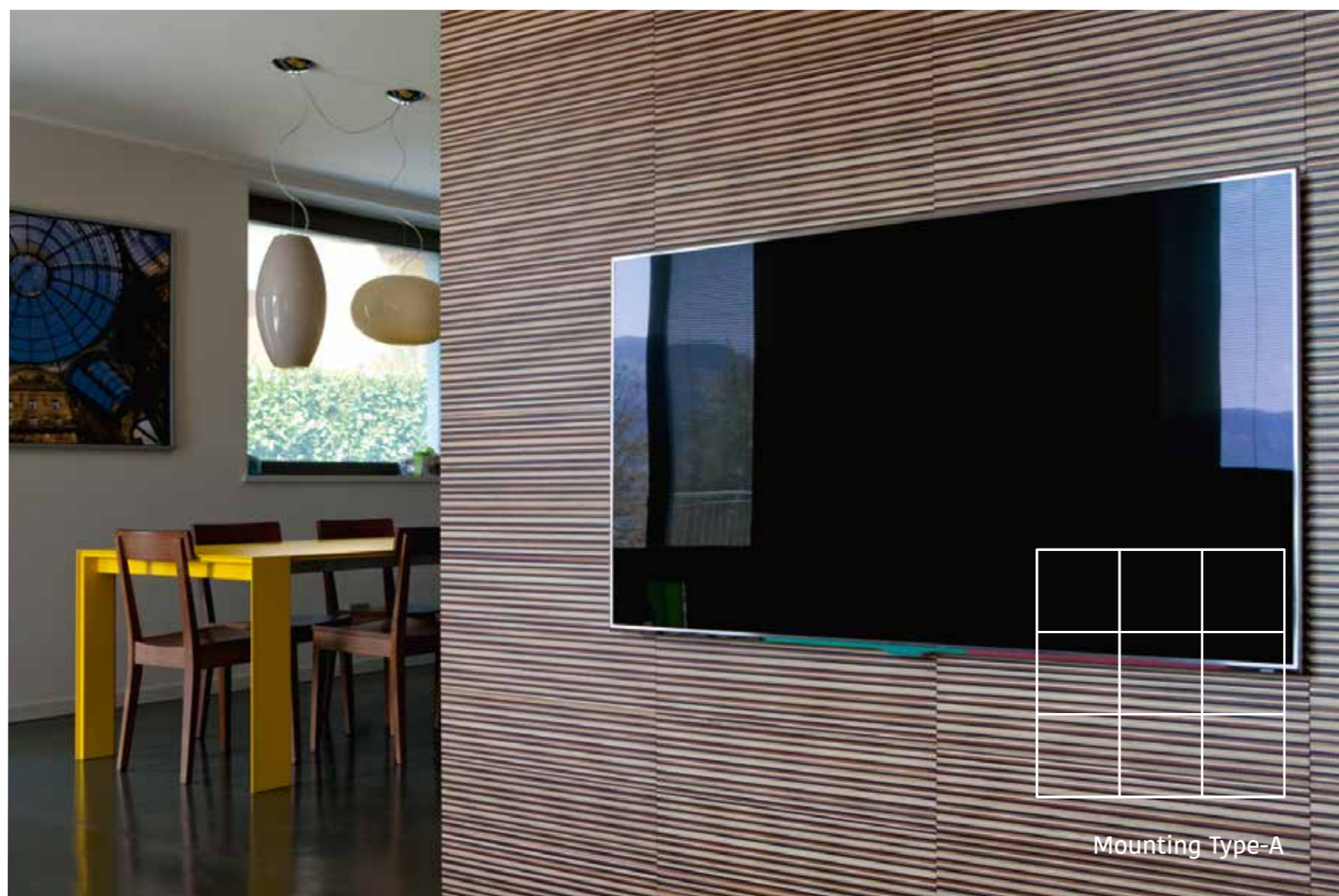

Multiline 580x580 Infinity Line

| 118 |

Mounting Type-A



Multiline 580x580 Infinity Line

| 119 |

Mounting Type-A

p. 122 Palace Sizes
p. 124 Palace Versailles Oak Natural
p. 125 Palace Argyle Oak Limestone
p. 126 Palace Kucuksu A. Walnut Light
p. 127 Palace Alhambra Oak Antique Lava
p. 128 Palace Beauvallon Oak Extra White / Oak Black Pearl
Palace Fontainebleau Oak Natural
Palace Boucheron A. Walnut Natural
Palace Hermitage Oak Natural / A. Walnut Natural
p. 129 Palace Potala Oak Natural / A. Walnut Natural
p. 130 Palace Fontainebleau A. Walnut Natural
p. 131 Palace Buckingham Oak Sbiancato

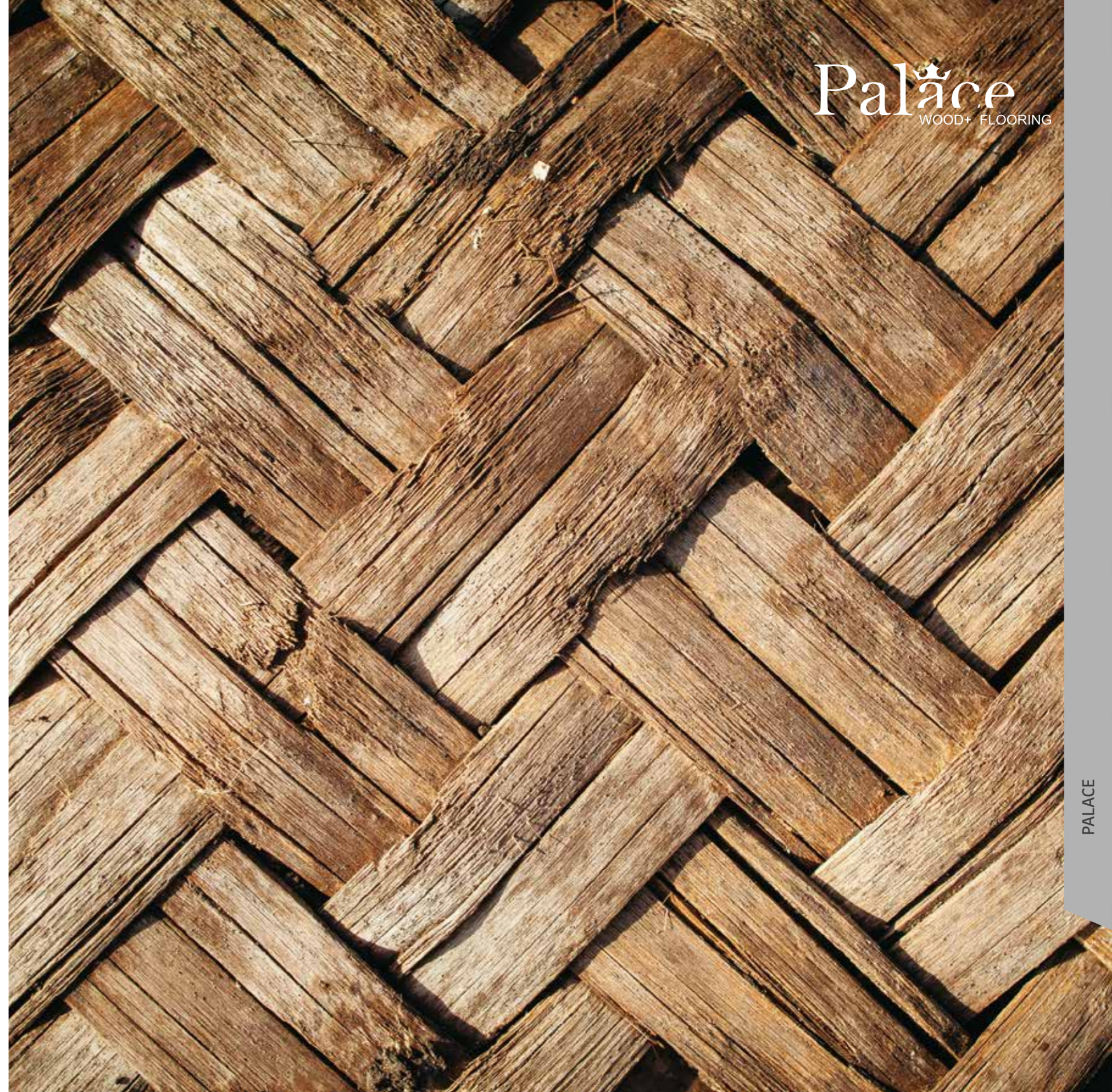

PALACE

SIZES

SIZES / FORMATOS / FORMATI / 尺寸及样式

Palace
WOOD+ FLOORING

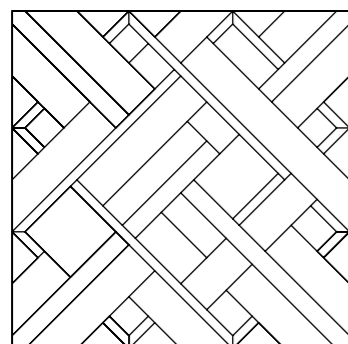

BOUCHERON
1160x1160
45,67"x45,67"

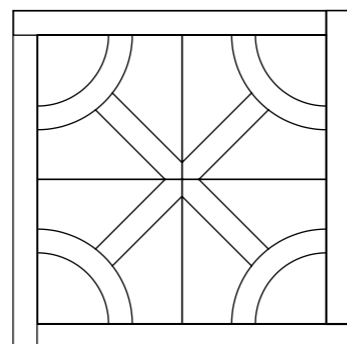

CHANTILLY
1160x1160 / 580x580
45,67"x45,67" /
22,83"x22,83"



Fontainebleau 580x580 Kempinski



Capodimonte 580x580 A. Walnut Honey

Available in all colors excepting dekape colors. Disponible en todos los colores excepto colores dekape. Disponibile in tutti i colori eccetto i colori dekape. 所有颜色都可生产, 除了DK拉丝色

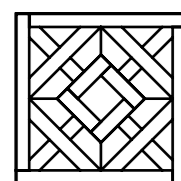

ALHAMBRA
580x580
22,83"x22,83"

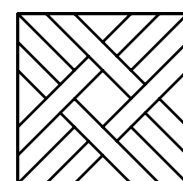

ARGYLE
580x580
22,83"x22,83"

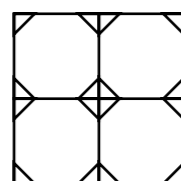

BEAUVALLON
580x580
22,83"x22,83"

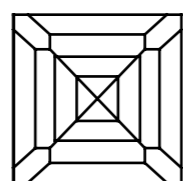

BUCKINGHAM
580x580
22,83"x22,83"

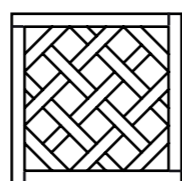

CAPODIMONTE
580x580
22,83"x22,83"

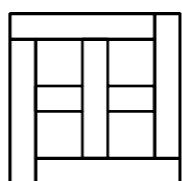

CROSS CASSETTE
580x580
22,83"x22,83"

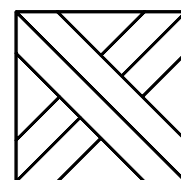

DOHA
580x580
22,83"x22,83"

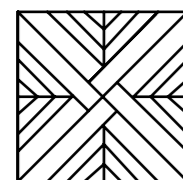

FONTAINEBLEAU
580x580
22,83"x22,83"

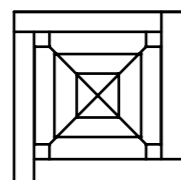

HERMITAGE
580x580
22,83"x22,83"

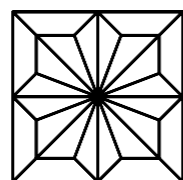

KUCUKSU
580x580
22,83"x22,83"

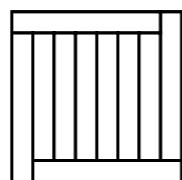

MONET
580x580
22,83"x22,83"

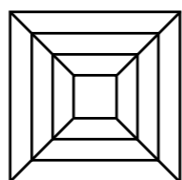

PALAIS ROYAL
580x580
22,83"x22,83"

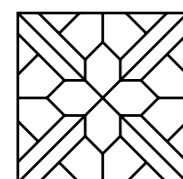

POTALA
580x580
22,83"x22,83"

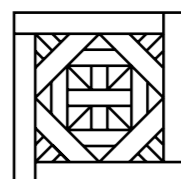

TAJ MAHAL
580x580
22,83"x22,83"

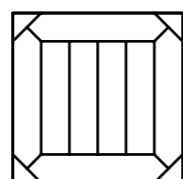

TOP KAPI
580x580
22,83"x22,83"

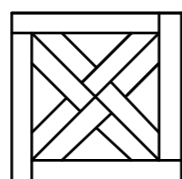

VERSAILLES
580x580
22,83"x22,83"

FINISH

FINISHES / ACABADOS / FINITURE / 成品

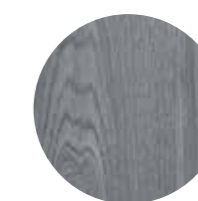

STANDARD FINISH

CLASSIC

CLASSIC is a UV brushed finish, with "oil-effect", micro-beveled on all four sides, open pore, resistant to moderate traffic. Gloss 5.

TRADITIONAL

TRADITIONAL is a UV brushed finish, with "oil-effect", micro-beveled on all four sides, open pore, with knots, resistant to moderate traffic. Gloss 5.

SPECIAL FINISH

TRAFFIC

TRAFFIC-BRUSHED is a UV brushed finish, with semi-gloss effect, micro-beveled on all four sides, open pore, resistant to intense traffic. Gloss 15.

SHINE

SHINE is a UV brushed finish, with high gloss effect, micro-beveled on all four sides, open pore, resistant to moderate traffic. Gloss 85.



Versailles 580x580 Oak Natural

| 124 |

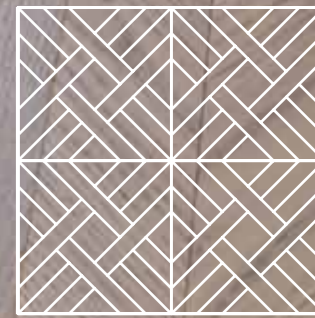

Argyle 580x580 Oak Limestone

| 125 |



Kucuksu 580x580 A. Walnut Light

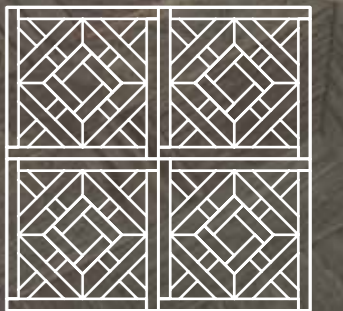
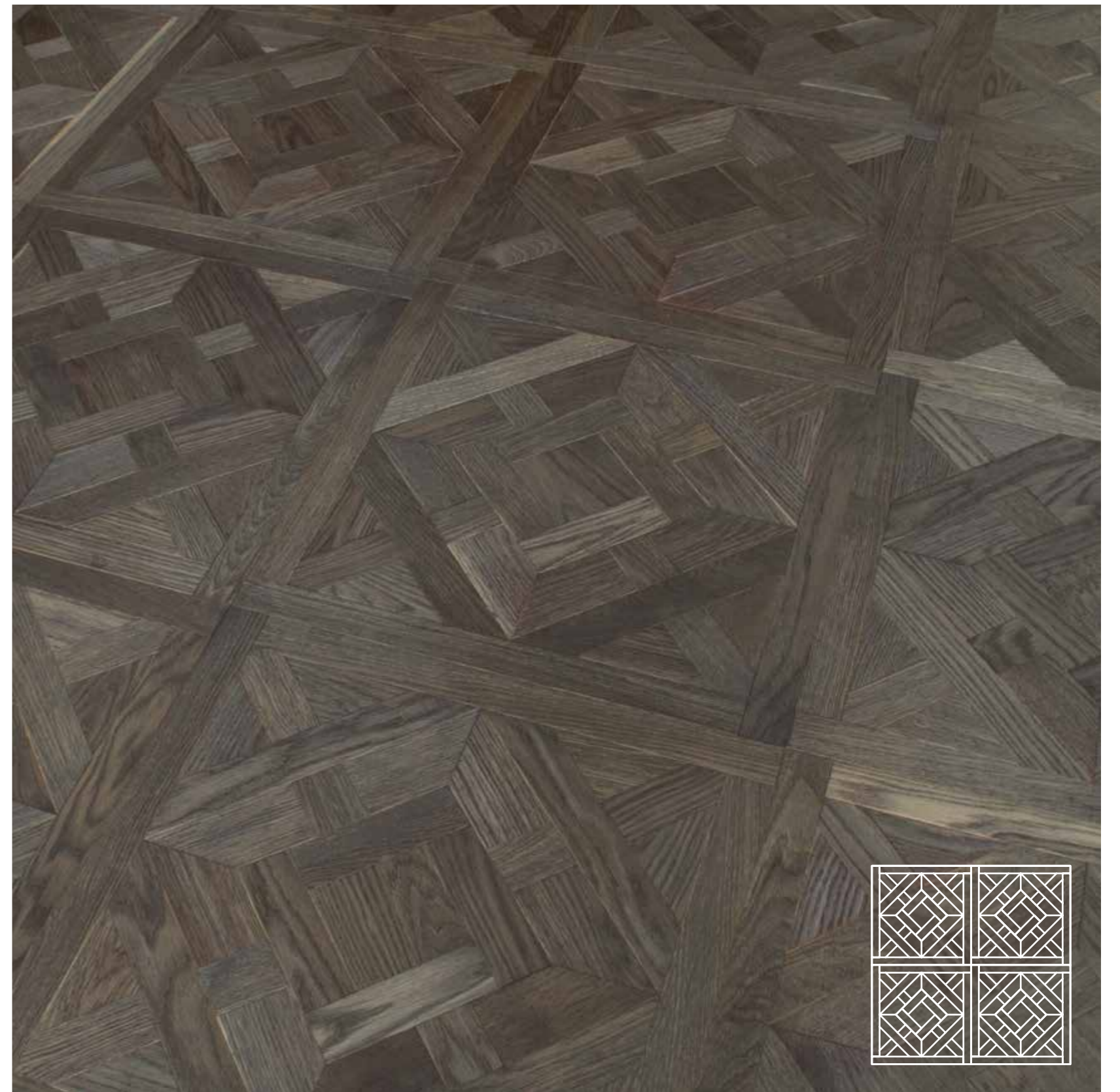

Alhambra 580x580 Oak Antique Lava



Beauvallon 580x580 Oak Extra White - Oak Black Pearl



Fontainebleau 580x580 Oak Natural

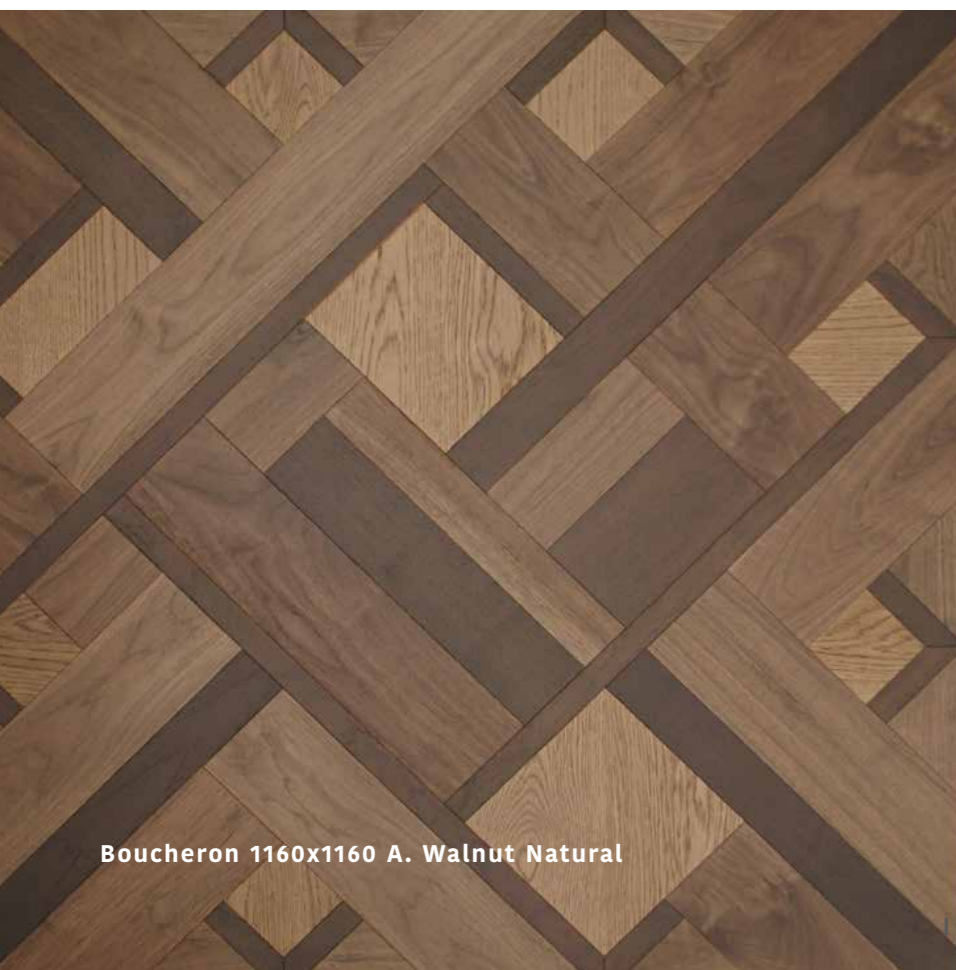

Boucheron 1160x1160 A. Walnut Natural

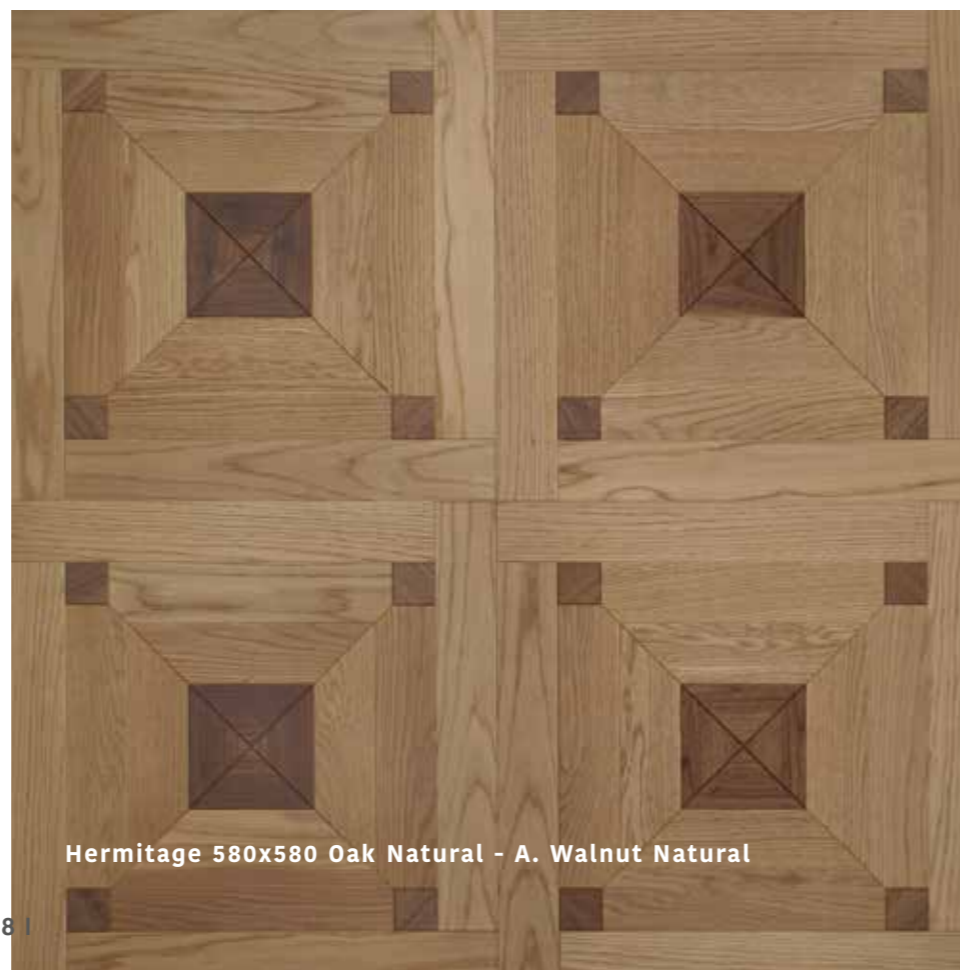

Hermitage 580x580 Oak Natural - A. Walnut Natural

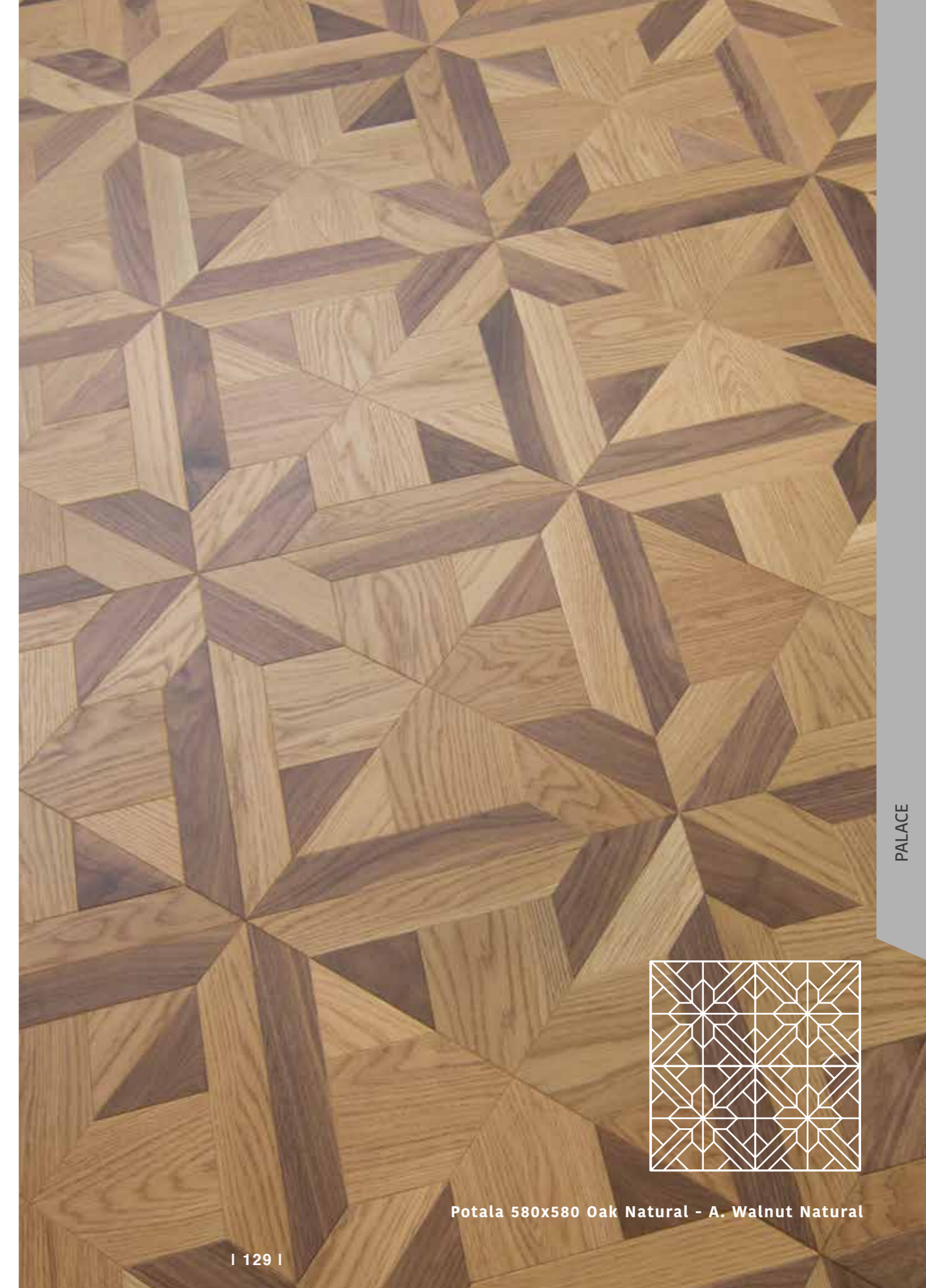

Potala 580x580 Oak Natural - A. Walnut Natural



Fontainebleau 580x580 A. Walnut Natural

| 130 |

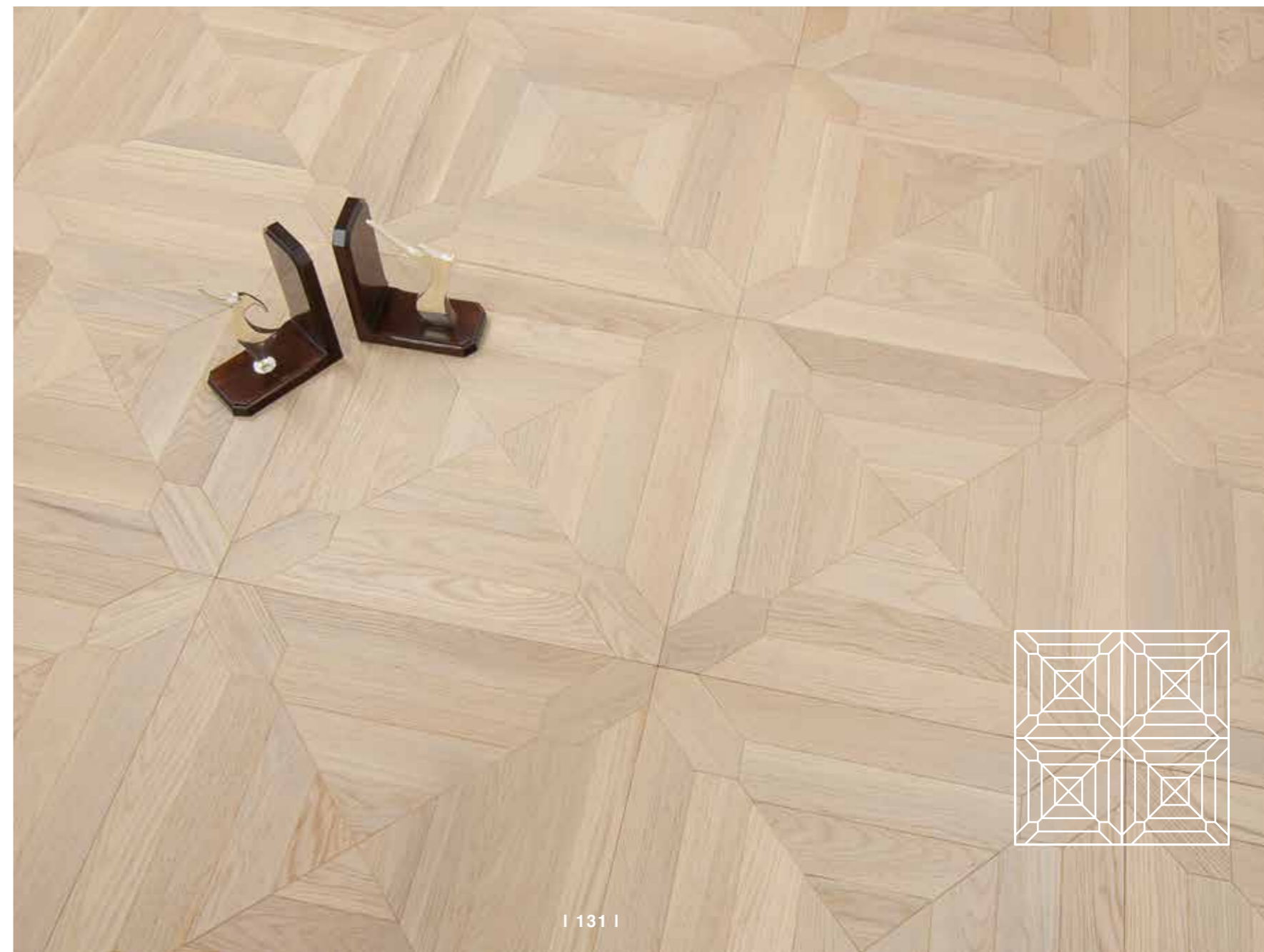

Buckingham 580x580 Oak Sbiancato

| 131 |

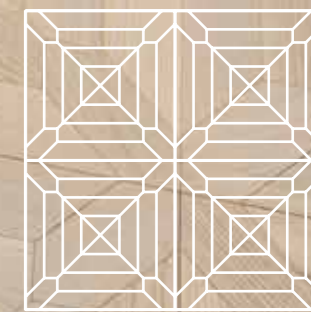

- p. 134 WoodMosaic Sizes
- p. 135 WoodMosaic Structure
- p. 136 WoodMosaic Installation Method
- p. 137 Stp Poxi
- p. 138 WoodMosaic A. Walnut Natural
- p. 139 WoodMosaic Oak Make Up White
- p. 140 Wood+ Oak DK Polar / WoodMosaic Oak DK Polar
- p. 141 WoodMosaic A. Walnut Honey
- p. 142 Wood+ Oak DK Polar / WoodMosaic Oak DK Polar
- p. 144 WoodMosaic A. Walnut Natural
- p. 145 Wood+ A. Walnut Natural / WoodMosaic A. Walnut Natural
- p. 146 WoodMosaic A. Walnut Light
- p. 147 WoodMosaic Wenge Natural

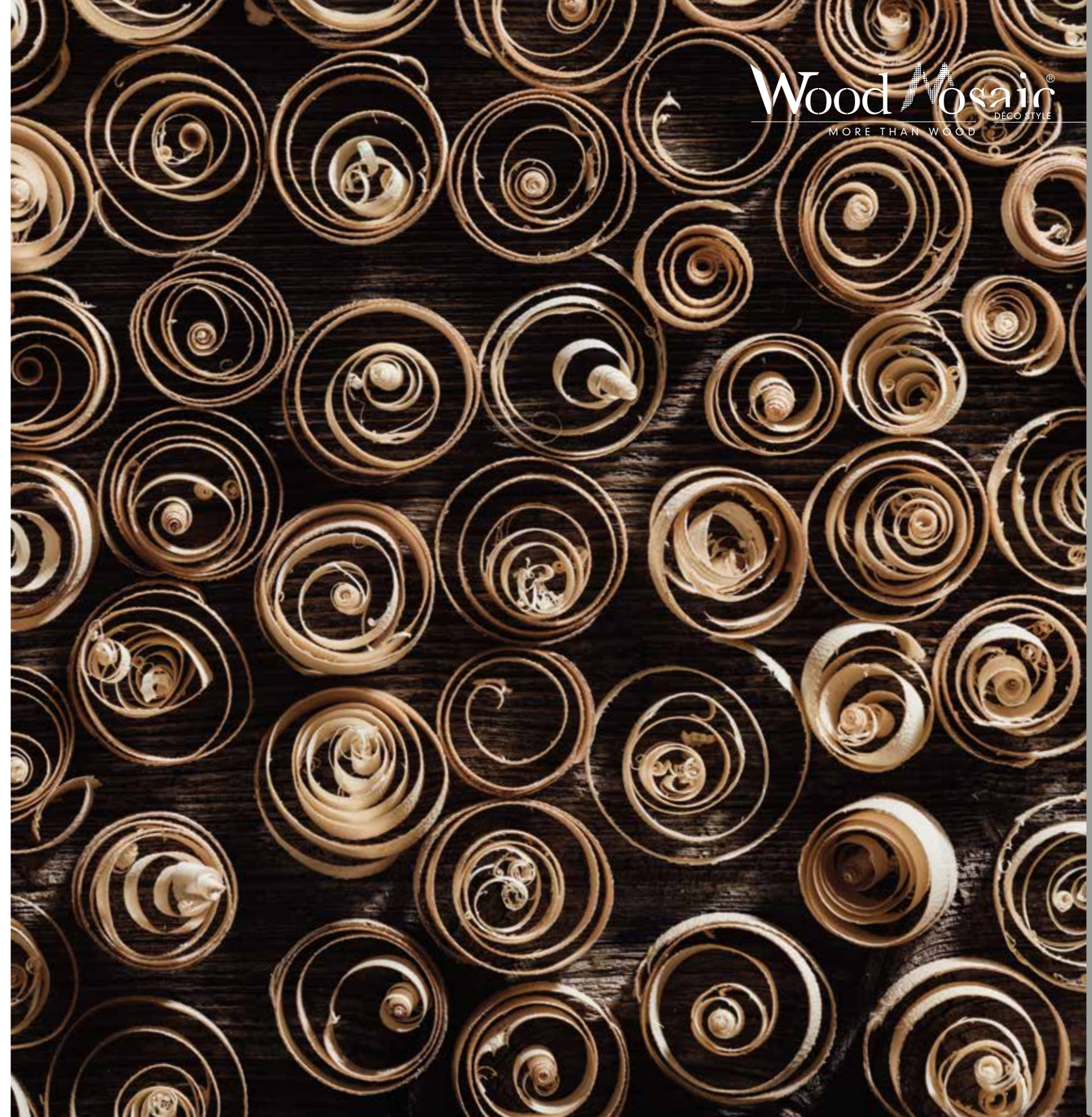

WOODMOSAIC

SIZES

SIZES / FORMATOS / FORMATI / 尺寸及样式

Wood Mosaic®
DÉCO STYLE

290 x 290
11,42"x11,42"

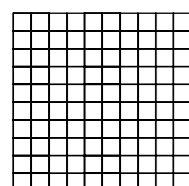

30 x 30
1,18"x1,18"

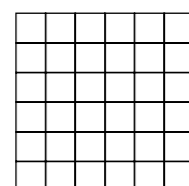

50 x 50
1,97"x1,97"

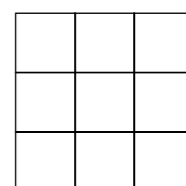

100 x 100
3,94"x3,94"

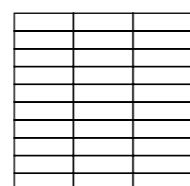

100 x 30
3,94"x1,18"

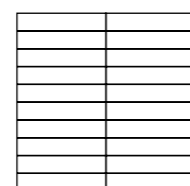

150 x 30
5,91"x1,18"

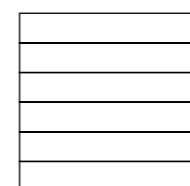

290 x 50
11,42"x1,97"



FINISHES

FINISHES / ACABADOS / FINITURE / 成品



TRAFFIC

TRAFFIC is a UV finish, with "oil-effect", micro-beveled on all four sides, close pore, smooth surface without brushing, resistant to intense traffic. Gloss 15. (TRAFFIC-BRUSHED, with brushed finish, open pore, available under request)
TRAFFIC es un acabado UV, con "efecto aceite", micro-biselado en los cuatro lados, poro cerrado, superficie lisa sin cepillado, resistente al tráfico intenso. Gloss 15. (TRAFFIC-BRUSHED, con acabado cepillado, poro abierto, disponible bajo pedido)
TRAFFIC è una finitura UV, ad "effetto olio", micro-bisellato sui quattro lati, poro chiuso, superficie liscia senza spazzolatura, resistente al traffico intenso. Gloss 15. (TRAFFIC-BRUSHED, con finitura spazzolata, poro aperto, disponibile su richiesta)
耐磨处理是一种UV面漆处理, 具有油效, 四边微倒角, 封闭孔, 光滑无拉丝, 超强耐磨。光泽度15度。(可按需定制耐磨拉丝表面处理, 开放孔)

Available in all colors excepting dekape colors.
Disponibile in todos los colores excepto colores dekape.
Disponibile in tutti i colori eccetto i colori dekape.
所有颜色都可生产, 除了DK拉丝色

STRUCTURE

ESTRUCTURA / STRUTTURA / 结构

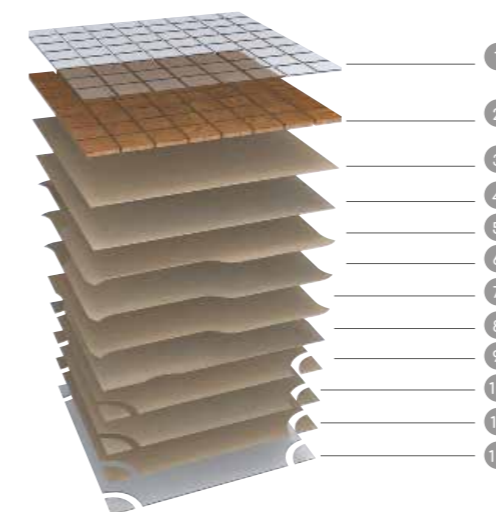

ENG

- 1st Overlay STP Traffic. High-performance protective overlay consisting of up to 12 coats combining stained, primer, and protective varnish, to give the product a resistant finish and create an oil effect at the same time. Gloss 15.
- 1st Layer. Noble wood of 3/4 mm thickness (depending on collection and finish), micro-beveled on all four sides.
- (3-11) Central Layer. Composed of 9 alternating layers of 100% birch plywood that works as an internal shaft and gives to the whole structure greater strength and stability (Thickness 12mm / 0.47").
- 2nd Overlay. Waterproofing varnish. Made of a layer of pore-filler varnish which helps to ensure the compact plan configuration of the piece.

ESP

- 1a Aplicación STP Traffic. Capa protectora de alto rendimiento compuesta por hasta 12 aplicaciones que combinan tinte, imprimación y barniz protector, para dar al producto un acabado resistente y crear un efecto aceite al mismo tiempo. Gloss 15.
- 1a Capa. Madera noble de 3/4 mm de espesor (según colección y acabado), micro-biselada en los cuatro lados.
- (3-11) Capa central. Compuesta por 9 capas alternas de contrachapado 100% abedul que funciona como eje interno y le da a toda la estructura una mayor resistencia y estabilidad (Espesor 12mm / 0.47").
- 2a Aplicación. Barniz impermeabilizante. Compuesto por una capa de barniz tapa poros que contribuye a garantizar la planimetría de la pieza.

IT

- 1a Applicazione STP Traffic. Pellicola protettiva ad alte prestazioni composta da un massimo di 12 mani che combinano vernice per la colorazione, primer e protettiva, per conferire al prodotto una finitura resistente e creare allo stesso tempo un effetto olio. Gloss 15.
- 1o Strato. Legno nobile di 3/4 mm spessore (a seconda della collezione e della finitura), micro-bisellato sui quattro lati.
- (3-11) Strato centrale. Composto da 9 strati alternati di multistrato di betulla 100% che hanno la funzione controbilanciante e conferisce a tutta la struttura maggiore resistenza e stabilità (Spessore 12mm / 0.47").
- 2o Applicazione. Vernice impermeabilizzante. Costituita da un strato di vernice per la chiusura dei pori che contribuisce a garantire la planarità del materiale.

CN

- 表层耐磨处理: 由多达12层的着色、底漆和保护清漆组成的高性能保护层, 给产品一个耐磨保护层, 同时创造一个油的效果。
- 第一层: 3/4毫米名贵实木层(取决于优异的选材和表面加工), 四边微倒角处理。
- 中间层(3-11): 由9层100%全桦木基材, 纵横交错组成, 使得整体结构超强坚韧及稳定(12mm厚度)。
- 底层: 防水漆面处理。由一层孔隙填料清漆制成, 有助于确保地板紧凑的平面配置。



Flexible format available under request
Formato flexible disponible bajo pedido
Formato flessibile disponibile su richiesta
可定制尺寸

MOSAIC INSTALLATION METHOD

MÉTODO DE INSTALACIÓN DEL MOSAICO / METODO DI INSTALLAZIONE DEL MOSAICO / 马赛克地板 - 马赛克地板安装方法

ENG INSTALLING THE MOSAIC

Either the adhesive-free LockSTP system or adhesives can be used to install mosaics on vertical surfaces. If using the adhesive installation method, STP recommends using EUROPOSA.

GROUTING THE MOSAIC

STP recommends using STP POXI* for grouting. STP POXI is an easy-to-clean, high-performance acid proof three-component epoxy sealant.

Use only on a dry, clean surface. Apply the product using the special rubber spatula provided. Using circular movements wash the surface with a damp cloth while the product is still wet, then clean with a stiff sponge for a smooth, sealed surface.

TECHNICAL FEATURES

The product will give maximum performance after 24 hours. For further information visit our website.

ESP PEGADO DEL MOSAICO

Para fijar el mosaico en superficies verticales, puede servirse del sistema sin cola LockSTP, u optar por la adhesión química. Si opta por la adhesión química, STP aconseja el uso de EUROPOSA como mejor mortero de pegado.

REJUNTADO DEL MOSAICO

STP aconseja el uso de STP POXI* como mejor mortero de rejunte. Es un mortero epoxídico antiácido tricomponente de extraordinarias prestaciones y gran facilidad de limpieza.

Utilizar siempre sobre soportes limpios y secos. Aplicar y trabajar siempre el producto con una espátula de goma. Limpiar el producto cuando aún está fresco ayudándose de abundante agua y una esponja de fieltro blanco realizado de movimientos circulares, y terminar con una esponja rígida para obtener una superficie lisa y cerrada.

CARACTERÍSTICAS TÉCNICAS

El producto alcanza las máximas prestaciones pasadas 24 horas. Para más información consulte el envase o visite nuestra website.

IT INCOLLAGGIO DEL MOSAICO

Per posare il mosaico in superfici verticali, può essere utilizzato il sistema senza colla LockSTP, oppure si può optare per l'utilizzo di collanti. Se si sceglie l'utilizzo di collanti, STP consiglia l'uso di EUROPOSA come prodotto ideale.

STUCCATURA DEL MOSAICO

STP consiglia l'uso di STP POXI* come prodotto ideale per le fughe. STP POXI è un sigillante epossidico antiacido tricomponente ad elevate prestazioni e di facile pulizia. Utilizzare sempre sulla superficie pulita e asciutta. Applicare il prodotto con l'apposita spatola di gomma. Lavare quando il prodotto è ancora fresco, utilizzare spugne in feltro bianco inumidito, eseguendo movimenti circolari, successivamente pulire con spugna rigida per ottenere una superficie liscia e chiusa.

CARATTERISTICHE TECNICHE

Il prodotto raggiunge le sue massime prestazioni dopo 24 ore. Per maggiori informazioni visitare il nostro sito.

CN 安装马赛克地板

LOCKSTP无胶锁扣安装，和传统胶水安装，均适用于马赛克地板的安装

马赛克地板填缝

STP推荐用STP POXI*给马赛克地板填缝。STP POXI是一种三组份环氧填缝剂，易清洁，抗氧化腐蚀。

只能在干燥、干净的表面使用。使用提供的特殊橡胶刮刀涂抹产品。当产品还是湿的时候，用湿布做圆周运动清洗表面，然后用硬海绵清洁表面，使产品表面光滑、密封。

技术特点

该产品在24小时后将发挥最大的性能。更多信息请访问我们的网站。

STP POXI[®]
ACID-RESISTANT JOINT

Mortar for sealing joints acid-resistant joints, from 0 to 10 mm. Low viscosity. Easy application. Mortero para el sellado de juntas ácido-resistentes, de 0 a 10 mm. Baja viscosidad. Fácil aplicación. Stucco per sigillatura di fughe acidoresistenti, da 0 a 10 mm. Bassa viscosità. Facile applicazione. 填缝剂用于密封接缝，使缝隙抗氧化耐腐蚀，从0到10mm。低粘度。简单应用。

COLORS

COLORS / COLORES / COLORI / 花色

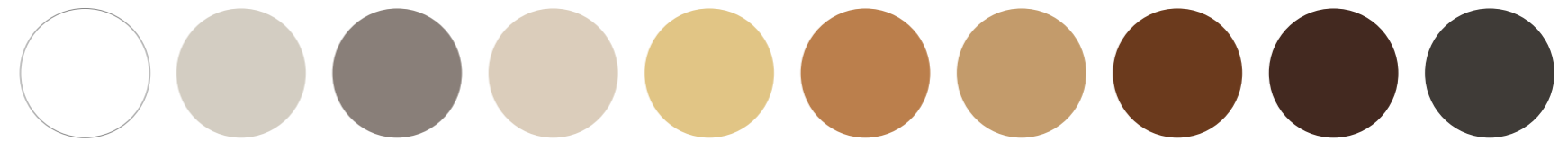

BLANCO
Nº0

GRIS CLARO
Nº8

GRIS CEMENTO
Nº9

BEIGE OSCURO
Nº2

ARCE
Nº85

ELONDO
Nº82

MARRÓN CLARO
Nº4

NOGAL
Nº88

WENGÉ
Nº86

NEGRO
Nº11

ENG

STP POXI is a three-component compound made using selected silica sand, stable pigments, and special additives which harden through a simple chemical reaction. Resulting in an exceptional product for:

- Optimal chemical resistance to detergents, corrosive acids, etc
- High mechanical resistance.
- Totally impermeable: 100%.

Please note that,

- STP POXI is not an expansion joint.
- Do not use the grouting material on wet, dirty, or dusty tiles.
- Take special care in cleaning sealing materials without varnishing.
- Do not make half and half mixes. Mix the total quantity of the three components.
- Do not add any other component to the STP POXI which could modify its characteristics.

ESP

STP POXI es un compuesto tricomponente elaborado con arenas silíceas seleccionadas, pigmentos estables y aditivos especiales, que se endurecen mediante una simple reacción química, dando como resultado un producto excepcional para:

- Óptima resistencia química a detergentes, ácidos corrosivos,...
- Elevadas resistencias mecánicas.
- Total impermeabilidad: 100%.

A tener en cuenta,

- STP POXI no son juntas de dilatación.
- No usar el material de rejuntado en piezas mojadas, sucias, llenas de polvo,...
- Tener especial precaución en la limpieza, cuando se rejuntan materiales sin barnizar.
- No realizar mezclas parciales. Mezclar los tres componentes por completo.

- No añadir ningún otro componente al STP POXI que pudiera modificar sus características.

IT

STP POXI è un composto tricomponente a base di sabbie silicee selezionate, pigmenti stabili e aditivi speciali, che induriscono semplicemente per reazione chimica, garantendo un prodotto eccezionale per:

- Ottima resistenza chimica a detergenti, acidi corrosivi, ecc...
- Elevate resistenze meccaniche.
- Totale impermeabilità: 100%.

Considerare,

- STP POXI non è indicato per i giunti di dilatazione.
- Non utilizzare il materiale di sigillatura delle fughe su mosaici bagnati, sporchi, coperti di polvere, ecc...
- Realizzare una pulizia particolarmente accurata qualora si esegua la sigillatura di fughe su materiali non verniciati.
- Non eseguire impasti parziali. Impastare tutta la quantità in dotazione dei tre componenti.
- Non aggiungere a STP POXI nessun altro componente che possa alterarne le caratteristiche.

CN

STP POXI填缝剂是一种三组分化合物，由精选的硅砂、稳定的颜料和特殊添加剂制成，通过简单的化学反应固化。其特点为：

- 耐腐蚀、抗氧化
- 超强耐磨
- 100%防水

但请注意：

- STP POXI填缝剂没有伸缩缝作用
- 不要在潮湿、肮脏或尘土飞扬的产品表面使用填缝剂
- 在清洗填缝剂时要特别小心，不要给填缝剂染上颜色
- 不要部分混合三组份，要将这三种成分全部混合在一起使用
- 不要添加任何其他成分，不然会改变填缝剂的性能

WoodMosaic 290x290 A. Walnut Natural - 50x50 Tessere



WoodMosaic 290x290 Oak Make Up White - 50x50 Tessere



580x580 Oak DK Polar - WoodMosaic 290x290 Oak DK Polar - 50x50 Tessere

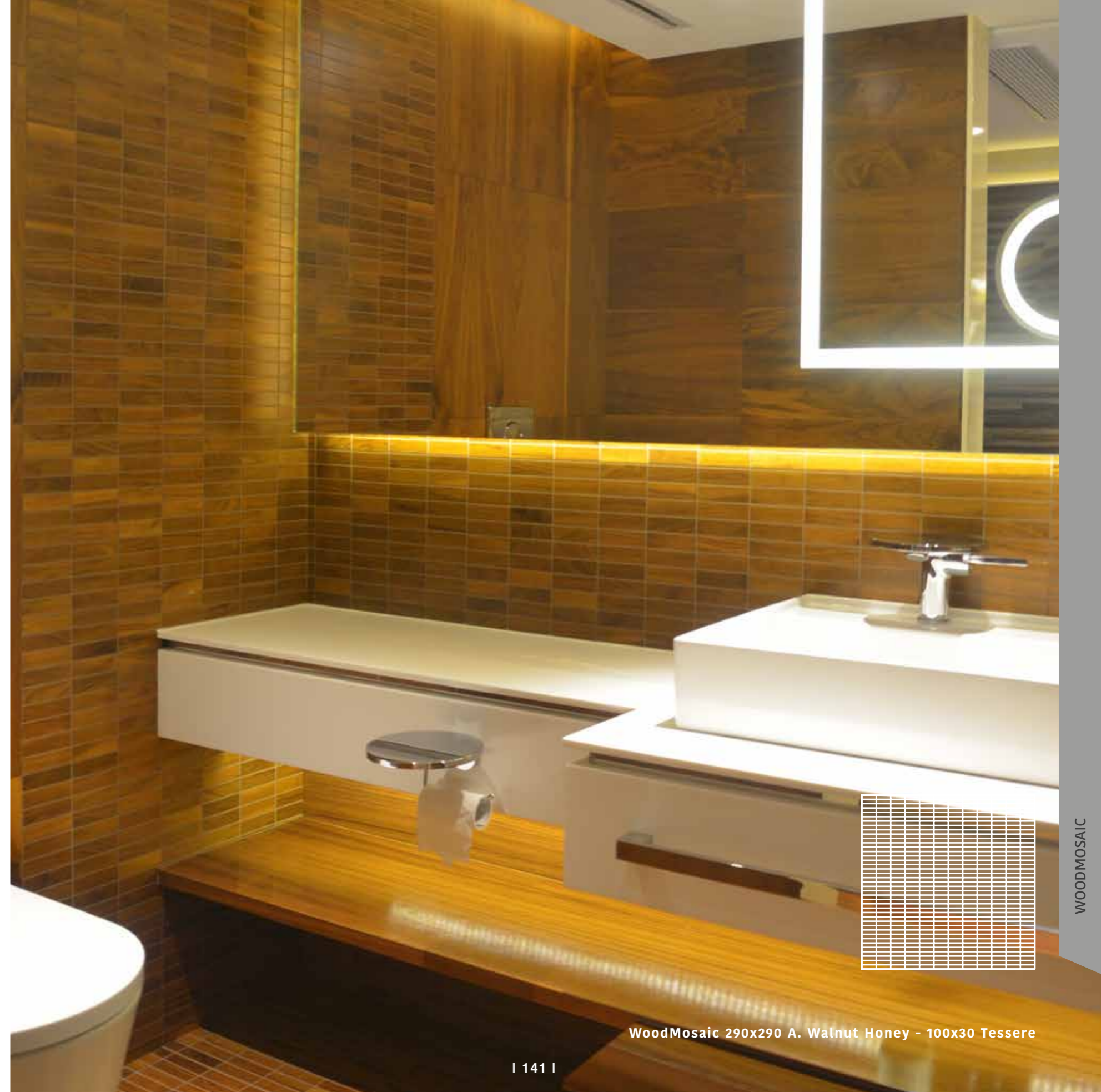

WoodMosaic 290x290 A. Walnut Honey - 100x30 Tessere



1160x580 Oak DK Polar
WoodMosaic 290x290 Oak DK Polar - 50x50 Tessere

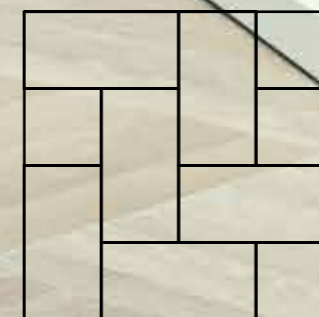

Mounting Type-H



WoodMosaic 290x290 A. Walnut Natural - 100x30 Tessere

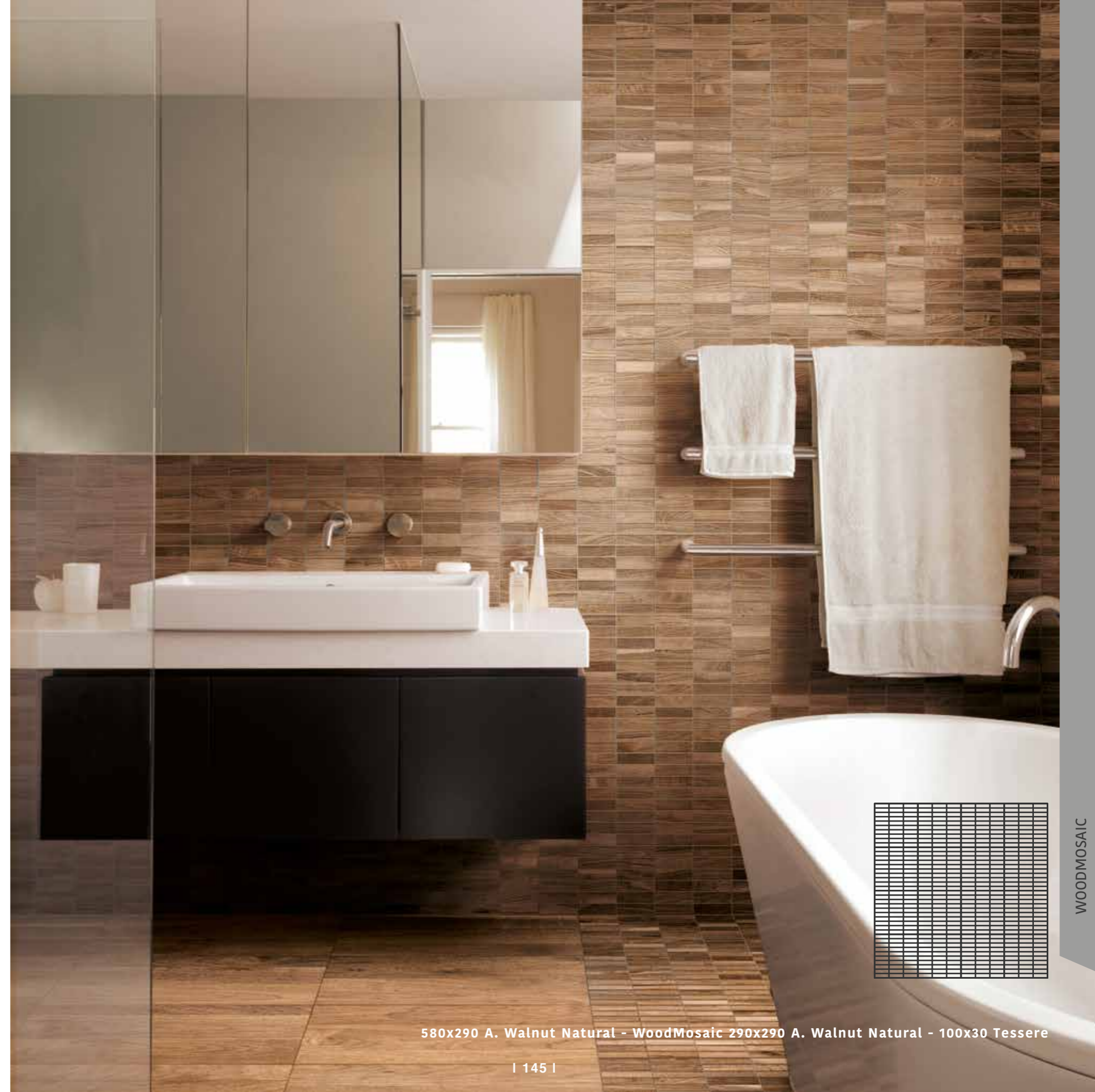

580x290 A. Walnut Natural - WoodMosaic 290x290 A. Walnut Natural - 100x30 Tessere

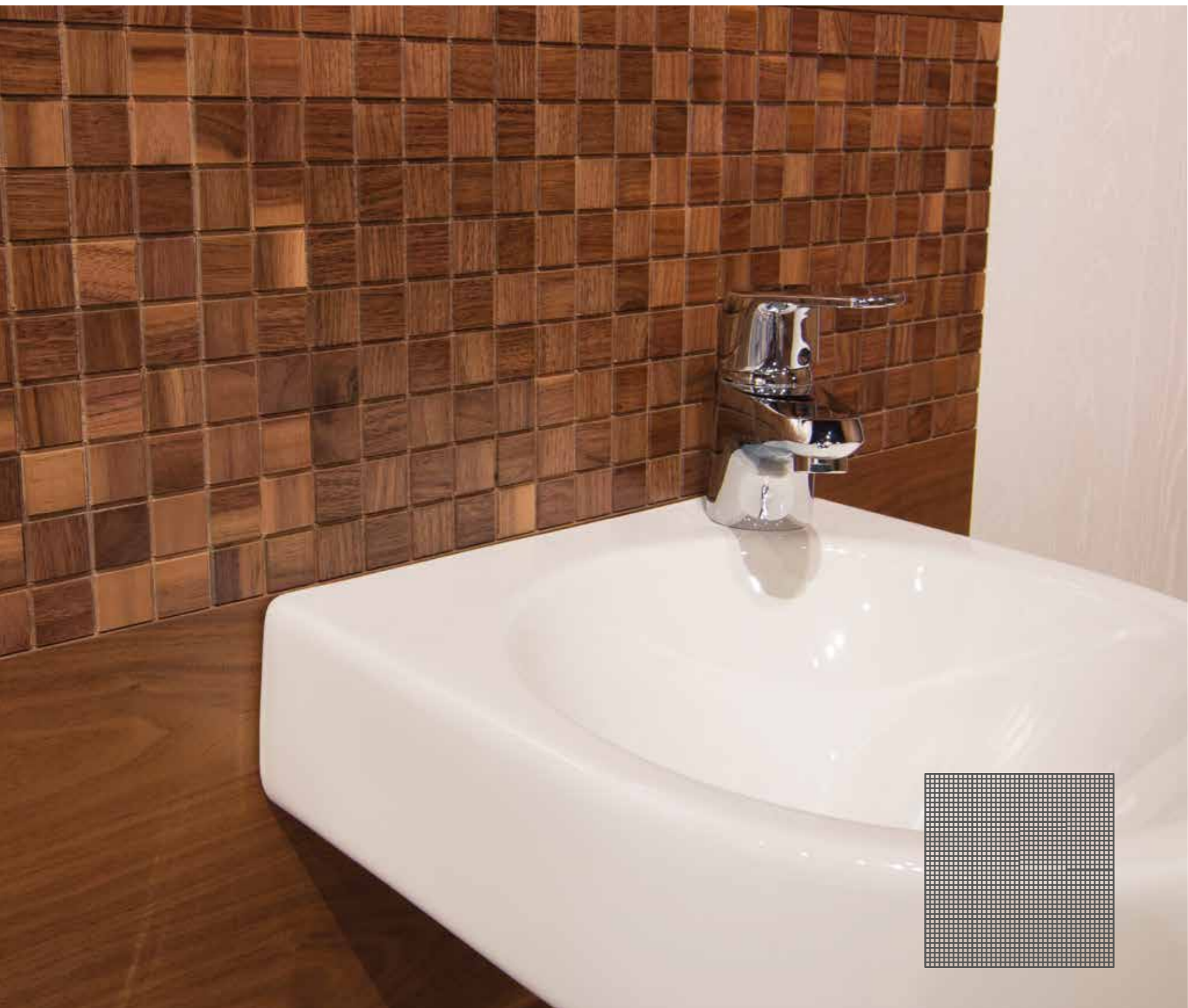

WoodMosaic 290x290 A. Walnut Light - 30x30 Tessere

| 146 |



WoodMosaic 290x290 Wenge Natural - 100x30 Tessere

| 147 |



TECHNICAL FEATURES

TECHNICAL FEATURES

TECHNICAL FEATURES / INFORMACIÓN TÉCNICA / INFORMAZIONI TECNICHE / 技术特点

SIMB	FEATURES / CARACTERISTICAS CARATTERISTICHE / 产品特性	NORM / NORMA / NORMA / 产品标准	NORM VALUE VALORES NORMA VALORI NORMA 标准评估	STP VALUE / VALORES STP VALORI STP / 价值
	Level of use Clase de Uso Classe d'uso 使用等级	EN 685	-	Classic Traditional Lux Traffic
	Abrasion resistance Resistencia a la abrasión Resistenza all'abrasione 耐磨性	EN 14354 Anexo D	WR2 IP > 5000 WR3 IP > 7000	Classic/Traditional/Lux WR2IP=5000 Traffi c WR3 IP=9000
	Impact resistance Resistencia al impacto Resistenza all'impatto 防撞性	EN 14354 Anexo C	EC2 > 1200 mm	EC2
	Formaldehyde emission Emisión Formaldehído Emissione Formaldeide 甲醛释放	EN 717-2:95	E1	E1
	Biological durability Durabilidad biológica Durabilità biologica 生物持久性	EN 355-1 y 2	-	Clase 1
	Fire reaction Reacción al fuego Reazione al fuoco 防火等级	EN 13501	-	Clase C _{fl-s1}
	Skid resistance Resistencia al deslizamiento Resistenza allo scivolamento 防滑性	EN 13893	-	Clase DS
	Thermal conductivity Conductividad térmica Conduttività termica 导热系数	EN 12524	-	0,17 W/mk
	Breaking strength (maximum load) Resistencia a la rotura (carga máxima) Resistenza alla rottura (carico massimo) 断裂强度 (最大负荷)	-	-	PND
	CE certificate / Certificado CE Certificato CE / CE认证	EN 1432:2006	SI	SI
	Density / Densidad / Densità / 密度	-	-	706 (26) Kg/m ³
	Dimensional stability / Estabilidad dimensional / Stabilità dimensionale / 稳定性	EN 1910	-	Paralelo - Parallelo - Paral. 0,13 mm Perpend - Perpendicolare - Perp. 0,66 mm
	Moisture content Contenido en humedad Contenuto umidità / 含水量	-	-	9,90 (0,74) %

PRODUCT	Two layers pavement
SUPPORT	9 alternating layers of 100% birch engineered plywood
THICKNESS	15/16 mm (depending on series and finish)
INSTALATION	Floating with no adhesive or glue down
TECHNOLOGY	LockSTP / T&G

PRODUCTO	Pavimento y revestimiento bicapa
SOPORTE	9 capas alternas de madera contrachapada 100% abedul mecanizadas
ESPESOR	15/16 mm (dependiendo de colección y acabado)
INSTALACIÓN	Flotante en seco o encolada
TECNOLOGÍA	LockSTP / T&G

PRODOTTO	Pavimento e rivestimento a due strati
SUPPORTO	9 strati alternati di multistrato 100% betulla
SPESSORE	15/16 mm (dipendendo della collezione e la finitura)
INSTALLAZIONE	Flottante senza colla o incollata
TECNOLOGIA	LockSTP / T&G

产品	两层保护层
支持	100%全桦木基材，9层纵横交错结构
厚度	15或者16毫米（取决于不同系列和表面处理工艺）
安装	无胶悬浮安装和传统胶水安装
技术支持	LockSTP 全球专利锁扣安装系统 / T&G传统安装系统

FAPIMA 2025, S.L. C/ Pérez Bayer, 16-181 - 12540 Vila-real (Castellón)	
14	
EN 14342	
Pavimentos de madera para colocación flotante sin cola. Sistema LOCKSTP.	
Densidad y grosor:	706,26
Reacción al fuego (EN 13501):	Clase C _{fl-s1}
Emisión de formaldehído (EN 717-2):	E1
Resistencia a la rotura (carga máxima):	PND
Deslizamiento (EN 13983):	DS
Conductividad térmica (EN 12524):	0,17 W/m K
Durabilidad biológica:	Clase 1



The mark of responsible forestry

CERTIFICATION FSC®, which identifies the products containing wood originated from forests which are managed in a correct and responsible way according to rigorous environmental, social and economical standards. The originating forest is controlled and valued independently according to these standards (principles and rules for a good forest management) which are established and approved by the Forest Stewardship Council a.c. with the participation and the consent of the involved parts. FSC under request.



The mark of responsible forestry

ENVIRONMENTAL CERTIFICATIONS

CERTIFICACIONES MEDIO AMBIENTALES / CERTIFICAZIONI AMBIENTALI / 证书



CE

All pre-finished STP products have a CE certificate (ref. Law EN 14342:2006). The CE directive urged by the fact that all construction elements should be conceived and produced to guarantee the security of human beings, animals and objects allow the introduction on the European market only of those products created with the characteristics provided for by the CE regulation.

The most important characteristics of pre-finished parquet floorings are described by the CE-label, which is specified through DIN EN14342 in turn. In addition to the release of formaldehyde and pentachlorophenol, slipping performance, heat conductance, breaking resistance, and biological durability, the fire-related properties of wooden- and parquet floorings are classified too.

Todos los productos STP pre-acabados poseen el certificado (ref.Norma EN 14342:2006). La directiva comunitaria sobre el mercado CE, fue concebida para garantizar la seguridad de personas, cosas o animales, lo que permite la introducción en el mercado Europeo únicamente de los productos creados acorde a las características requeridas por regulación CE. Las características más importantes de los productos de parquet poseedores del mercado CE, (DIN EN14342:2006) son: La emisión de formaldehído y el pentaclorofenol, la resistencia al deslizamiento, la conductividad de térmica, la resistencia a la rotura y la durabilidad biológica, así como las propiedades relativas a la reacción al fuego del parquet o de otros tipos de suelos de madera.

Tutti i prodotti STP sono certificati CE (rif. norma EN 14342:2006). La direttiva comunitaria sulla marcatura CE è stata concepita per garantire la sicurezza di persone, cose e animali, permettendo l'immissione sul mercato europeo unicamente di prodotti creati con le caratteristiche previste dalla legge.

Le caratteristiche principali dei prodotti da parquet che posseggono il marchio CE sono: L'emissione di Formaldeide, il pentaclorofenolo, resistenza allo scivolamento,Conduttività termica, Resistenza alla rottura, e la durabilità biologica, oltre alle proprietà relative alla reazione al fuoco del parquet o di altri tipi di pavimenti in legno.

所有STP产品都有CE证书(参考法律EN 14342:2006)。CE证书的要求是，所有建筑元素的构思和生产都应保证人类、动物和物体的安全，因此只允许将符合CE法规所规定的特性的产品引入欧洲市场。预加工的地板的最重要特征通过ce标签进行描述，该标签依次通过DIN EN14342进行规定。除了释放甲醛和五氯酚、防滑性能、热导性、抗断裂性和生物耐久性外，木地板的防火性能也进行了分类。

FSC

FSC® CERTIFICATE, which identifies the products containing wood originated from forests that are managed in a correct and responsible way according to rigorous environmental, social, and economical standards.

The originating forest is controlled and evaluated independently according to these standards (principles and rules for a good forest management) which are established and approved by the Forest Stewardship Council a.c. with the participation and the consent of the involved parties. FSC under request.

CERTIFICACIÓN FSC®, identifica los productos que contienen madera de bosques de tala controlada de manera correcta y responsable de acuerdo con rigurosos estándares ambiental, social y económico.

El bosque en su origen es controlado y evaluado de forma independiente de acuerdo con estos estándares (principios y criterios de buena gestión forestal), establecidos y aprobados por el Forest Stewardship Council a.c. a través de la participación y el consentimiento de las partes interesadas. FSC bajo pedido.

CERTIFICAZIONE FSC®, che identifica i prodotti contenenti legno proveniente da foreste gestite in maniera corretta e responsabile secondo rigorosi standard ambientali, sociali ed economici.

La foresta di origine è controllata e valutata in maniera indipendente in conformità a questi standard (principi e criteri di buona gestione forestale), stabiliti ed approvati da Forest Stewardship Council a.c. tramite la partecipazione e il consenso delle parti interessate. FSC su ordinazione.

FSC®证书，该证书识别了根据严格的环境、社会和经济标准以正确和负责任的方式管理来自森林的木材产品。原始森林是根据这些标准(良好森林管理的原则和规则)进行独立控制和评价的，这些标准由森林管理委员会在有关各方的参与和同意下制定和核准。

*STP reserves the right to withdraw, change, amend, modify the colors, species, dimensions, specifications, products, policies or procedures described in this catalog.

ENVIRONMENTAL CERTIFICATIONS

CERTIFICACIONES MEDIO AMBIENTALES / CERTIFICAZIONI AMBIENTALI / 环保证书



FORMALDEHYDE EXEMPT

In full respect of the class E1 limits of the norm UNI EN 717-2:95, as emerging from the analysis conducted by AIDIMA, an accredited laboratory for analysis testing.

En concordância com los límites establecidos por la norma UNI EN 717-2:95 Clase E1, tal y como se muestra en el estudio realizado por AIDIMA, laboratorio acreditado para estas pruebas de análisis.

Pieno rispetto dei limiti per la classe E1 della norma UNI EN 717-2:95, come emerge dalle analisi condotte dal AIDIMA, laboratorio accreditato per prove di analisi.

完全遵守规范UNI EN 717-2:95的E1级，由AIDIMA(分析测试的认可实验室)进行的分析得出。



FIREPROOF CERTIFICATION

In full respect of the class Cfl-s1 limits of the norm EN 13501, as emerging from the analysis conducted by AIDIMA, an accredited laboratory for analysis testing.

En concordância com los límites establecidos por la norma EN 13501 Classe Cfl-s1, tal y como se muestra en el estudio realizado por AIDIMA, laboratorio acreditado para estas pruebas de análisis.

Pieno rispetto dei limiti per la classe Cfl-s1 della norma EN 13501, come emerge dalle analisi condotte dal AIDIMA, laboratorio accreditato per prove di analisi.

Cfl-s1, 严格遵守EN 13501的标准限值，由AIDIMA(分析测试的认可实验室)进行分析产生。



ANTIBACTERIAL

For its wooden floorings, STP developed finishing varnishes with hygienic activity reducing the bacterial load to 99.99%. The biocide action can result through the interaction with biological target structures, or through interferences in the cell metabolic and energetic processes; in other words, blocking the bacteria's breathing provoking its death as a consequence. The wooden floors treated with these varnishes enable to have a first precaution in case there is a need to reduce bacterial contamination in a short time, especially when it might be very difficult to guarantee a deep cleansing due to the position of the base itself or in public environments where an immediate hygienic action may be necessary. The treatment is particularly suitable for wooden floors in houses or environments with pets.

STP ha desarrollado para sus suelos de madera barnices con actividad higienizante, lo que logra reducir la carga bacteriana en un 99,99%.

La acción bactericida viene dada por la interacción con las estructuras biológicas o por medio de interferencias en el metabolismo celular y los procesos energéticos, es decir, bloquear la respiración de las bacterias provocando como consecuencia su muerte. Los suelos de madera tratados con estos barnices permiten una primera prevención a corto plazo en caso de necesidad de reducción de la contaminación bacteriana, especialmente cuando sería verdaderamente difícil garantizar una profunda higiene debido a la colocación del propio suelo o en ambientes públicos en los que se requiera una inmediata acción de limpieza. El tratamiento está especialmente indicado para los pavimentos de madera en casa o ambientes con animales domésticos.

STP ha sviluppato delle vernici di finitura con attività igienizzante per il propri pavimenti in legno, che riducono la carica batterica del 99,99%. L'azione biocida può risultare attraverso l'interazione con strutture bersaglio biologiche, oppure attraverso interferenze in processi metabolici ed energetici della cellula; in altre parole bloccando la respirazione del batterio e provocandone di conseguenza la morte. I pavimenti in legno trattati con queste vernici forniscono una prima precauzione dove possa essere richiesta una riduzione della contaminazione batterica in tempi brevi, soprattutto dove può essere molto difficile garantire una pulizia profonda anche a causa della posizione del supporto stesso o in ambienti pubblici dove può essere utile garantire una azione igienizzante immediata. Il trattamento risulta particolarmente adatto per pavimenti in legno posti in ambienti o abitazioni frequentati da animali domestici.

对于实木地板，STP开发了具有卫生活性的表面清漆工艺，可以将细菌载量降低99.99%。生物杀灭作用可以通过与生物靶结构的相互作用，或通过干扰细胞的代谢和能量过程产生;换句话说，阻断细菌的呼吸从而导致其死亡。木质地板处理通过专门的清漆工艺处理使先有一个预防措施，以防有需要在短时间内减少细菌污染，特别是当它可能很难保证深度清洗由于基地本身的位置或在公共环境中立即卫生行动可能是必要的。这种处理方法特别适用于有宠物的房屋或环境中的木地板

*STP reserves the right to withdraw, change, amend, modify the colors, species, dimensions, specifications, products, policies or procedures described in this catalog.



BIOLOGICAL DURABILITY

STP complies with the norm EN 335-1 & 2 Use Class 1. It means that the risk of surface attack by molds or mushrooms can be caused, the blueness or ligniperdous mushrooms is unimportant.

STP cumple con la norma EN 335-1 & 2 Clase de uso 1. La cual reduce el riesgo de que la superficie se vea dañada por el ataque de hongos o moho, el florecimiento o los ligniperduos no constituyen una amenaza importante.

STP soddisfa la norma EN 335-1 & 2 Clase de uso 1. Ciò riduce il rischio che la superficie sia attaccata da muffa o funghi, l'umidità e ligniperdous non è una grave minaccia.

STP符合标准EN 335-1和2的Class 1。这意味着表面有可能会引起霉菌攻击的风险，但没有青色或对木质有害的蘑菇菌



SOLVENT FREE

During the complementary manufacturing, in the lacquering and UV varnishing cycles, and during the use of adhesives, there is no emission of solvents in the atmosphere, harmful to human-beings and the environment.

Durante el proceso de fabricación complementaria, en uso de adhesivos, el lacado y el barnizado UV, no existe ningún tipo de emisión a la atmósfera de disolventes perjudiciales para los seres humanos o para el medio ambiente.

Nelle lavorazioni complementari, nei cicli di verniciatura e oliatura UV e nell'utilizzo di collanti non vi è alcuna emissione di solventi in atmosfera, nocivi per l'uomo e l'ambiente.

在完整的生产过程中，在表面漆和UV漆循环过程中，在使用粘合剂的过程中，没有任何对人类和环境有害溶剂排放到大气中。



VOC EMISSIONS

STP products fulfill the requirements established for Class A+ in the Decree No. 2011-321 of March 23, 2011 of the French Ministry of Ecology, Sustainable Development, Transport, and Housing.

Los productos STP cumplen los requisitos de la Clase A+ del decreto N° 2011-321 del 23 de marzo de 2011 del Ministerio Francés de Ecología, Desarrollo Sostenible, Transporte y Vivienda.

I prodotti STP soddisfano i requisiti stabiliti per la Classe A+ nel Decreto n. 2011-321 del 23 marzo, 2011 del Ministero Francese dell'Ecologia, dello Sviluppo Sostenibile, dei Trasporti e dell'Edilizia Abitativa.

STP产品完全符合2011-321号法令标准的A+等级，该法令是2011年3月23日颁布的。



STP NOTABLE PROJECTS

PROYECTOS DESTACADOS STP / STP PROGETTI NOTEVOLI / STP 著名项目案例

CANADA

1250 Ave Greene, Condo building
 Abbey, Hotel
 AC Cuisines, Retail
 Ardene, Corporate Head Office
 Beatrice, Restaurant
 Birks, Retail
 Boullon Bilk, Restaurant
 BROCCOLINI, Corporate Head Office
 Chateau d'ivoire, Jewelry store
 Clairview leasing, Head office
 Clusier, Retail
 Condo du Musee, Condo building
 Corus, Corporate Head Office
 Deloitte, Corporate Head Office
 Ernest & young, Corporate Head Office
 Etiket, Retail
 Four Seasons, Hotel and residence
 HARRY ROSEN, Department store
 HBC, Department store
 Hilton Garden Inn, Hotel
 Jacobs & Co Steakhouse, Restaurant

Jewish General Hospital, Auditorium
 JJ Bean Coffee Roasters, Restaurant
 KING EDWARD, Hotel
 KLEINFELD BRIDAL, Retail
 Marcus, Restaurant
 Maxwell, Hotel
 Moretti, Pizzeria restaurant
 Okio Soins de la Vue, Retail store
 Ottawa Senators parliament
 Pastel, Restaurant
 Presti, Head office
 Royal Quai, Residential project
 Rudsak, Retail
 St. Regis, Hotel
 SAKS Fifth Avenue, Department store
 Saputo Stadium
 Simons, Department store
 Sir George Simpson, Condo building
 Starbucks, Coffee House
 Urfelia, Retail
 WESTON Ltd., Corporate Head Office

CHINA

Wan Feng Hui, Condo building
 Hua Run, Condo building
 Yanlord, Private residences
 Yating Villa, Private residences

CYPRUS

AMAVI Made for Two™, Luxury hotel
 CC MARKET INTERNATIONAL, Corporate Head Office
 CDA Offices, Corporate Head Office
 NUMA Boutique, Retail

FRANCE

BEAUVALLON, Hotel
 Rive Gauche, Restaurant

HOLLAND

Amsterdam University
 World Fashion Center

HONG KONG

Park Lane - Pullman, Hotel
 Hang Hau Wing Lung Road, Condo building
 Lo Fai Road, Condo building
 Stubbs Road, Condo building
 Beacon Hill Road, Condo building
 Castle Peak Road, Condo building

INDIA

JSW, Restaurant

ISRAEL

Houzz, Corporate Head Office

ITALY

ACCADEMIA, Hotel
 BANCA INTESA, Corporate Head Office
 Conca d'Oro, Condo building
 CONFINDUSTRIA Varese, Corporate Head Office
 ROLEX, Corporate Head Office and main showroom
 RUBENS, Hotel
 STAR, Hotel
 VILLA NECCHI, Hotel

KAZAKHSTAN

Dostyk, Hotel

LITHUANIA

Gulbinu str., Condo building
 Turniskiu str., Condo building
 Lauru str., Condo building

Kazimiero str., Condo building
 Uztvanku str., Condo building
 Sodziaus meistrai, Public institution

MEXICO

Museo Banco de México

NORWAY

Thiis - gården, Condo building
 Skybar at Radisson Hotel, Restaurant

PERÚ

CEM IV, Building
 ILARIA INTERNACIONAL, Retail

PORTUGAL

Cliff Bay, Hotel

PUERTO RICO

SAKS Fifth Avenue, Department store

RUSSIA

GAZPROM, Corporate Head Office
 The State Corporation Deposit Insurance Agency

SINGAPORE

LULULEMON, Retail

SOUTH KOREA

Chanel, Flagship store
 SHINSEGAE GANGNAM, Department store
 Boucheron Lotte Department, Retail

SPAIN

Casa Emiliana, Restaurant
 "José Hernández Quero", Centro de Arte y

Biblioteca en Palacio Ruiz de Castro
 MAKKILA, Restaurant
 NH Collection Valencia, Hotel
 Vila-real City Hall

TURKEY

ANTTERAS, Residential Project
 CAVALLI, Retail
 Cinema Pink
 Glocal, Department store
 Grand Azur, Hotel
 YILDIZ ENTEGRE, Corporate Head Office

US

14 West, Condo building
 Austin Nichols House, Condo building
 BACCARAT, Hotel / Residence
 Brentwood Kitchen, Retail
 Bristol, Condo building
 CIBO Wine Bar, Restaurant
 Four Seasons, Hotel
 GE Monogram, Retail
 LULULEMON, Retail
 Momofuku, Restaurant
 SAKS Fifth Avenue, Department store
 Siematic Kitchen, Retail
 Transact, Corporate Head Office
 TWA Sales Center cooperate office



STP

Wood+ Flooring Industries

Central Offices & Factory Plant.

C/ Olocau del Rei 3D (transversal CV-20. km 2,5)

Apdo. correos / P.O. Box 211.

12540 Vila-real / Castellón / Spain

Tel. (34) 964 785 121

info@stp-woodflooring.com

www.stp-woodflooring.com

eurolegno distribution inc.

Canadian distribution & US agency

5333 Ferrier

Montreal, Quebec

Canada, H4P 1M1

Tel: # 001 - 514 - 739 - 9416

info@eurolegnoluxuryfloors.com



LOCKSTEP®
EXCELLENT GLUELESS SYSTEM

Patent-protected
worldwide



100% Made in Spain