



V23

100% Made in Spain

FiorWood®
ECO GREEN FLOORS - SLIM 3 LAYER TECHNOLOGY

STP®
PURE INNOVATION

THE FUTURE OF SLIM FLOORING

"Fiorwood is the new generation slim natural floor. It is traffic resistant, ecological and versatile. 100% made in Spain. The core structure is made of 100% birch plywood, Top layer is composed of 0,6mm European white oak WOOD, and the contrabalance on the bottom part of 0,6mm wood veneer. It is engineered with the worldwide patent LOCKSTP®".

EL FUTURO DE LA MADERA NATURAL RECHAPADA

"Fiorwood es la nueva generación de pavimentos y revestimientos rechapados en madera natural. Tiene una alta resistencia al tráfico, es ecológico, versátil y 100% fabricado en España. La estructura central está formada por contrachapado fenólico 100% abedul, la capa superior por 0,6mm de madera de roble blanco europeo y la subestructura, en la parte inferior, de madera rechapada de 0,6mm. Diseñado con la patente mundial Lockstp®".

轻薄地板的未来

Fiorwood是新一代轻薄的实木复合地板。它耐磨、环保和用途广泛。100%西班牙制造。它的核心结构是由100%全桦木基材，以及0.6mm欧洲白橡木实木面皮和0.6mm实木底层组成。带有全球专利的LOCKSTP®安装系统



FiorWood[®]
ECO GREEN FLOORS - SLIM 3 LAYER TECHNOLOGY



LOCK STP
LOCK STP
锁定STP®

Precision Tongue and Groove, the worldwide patent LockSTP® system is the unique system all over the world that allows to use a modular system, combining all STP® formats without the use of an adhesive.

La precisión del machihembrado con nuestro sistema LockSTP (patentado a nivel mundial), es el único sistema modular que permite combinar todos nuestros formatos disponibles sin necesidad de utilizar adhesivos.

Precision Tongue and Groove, 全球专利LocksSTP®系统是全世界独一无二的系统, 允许使用模块化系统, 不使用粘合剂即可组合所有STP®格式。



UNIQUE DESIGNS
DISEÑOS ÚNICOS
独特的设计

Fiorwood® presents an exciting and distinctive collection of colors and formats. Our unique design products allow to choose from a large selection of colors, styles and formats with an impressive range of dimensions, making each project unique and exclusive.

Fiorwood® ofrece una atractiva y variada gama de colores y formatos. Nuestros productos únicos de diseño permiten elegir entre una gran selección de colores, estilos y formatos con una impresionante diversidad de medidas, haciendo que cada proyecto sea único y exclusivo.

Fiorwood®展示了一个令人兴奋和独特的颜色和格式集合。我们独特的设计产品允许从大量颜色、风格和格式中进行选择, 尺寸范围令人印象深刻, 使每个项目都独一无二。



REAL WOOD
AUTÉNTICA MADERA NATURAL
真正的木头

Finished by brushed open pore that highlights the natural essence of the Real Wood, with the high traffic resistance coatings.

Acabado con poro abierto que realza la esencia de la Madera Natural, con recubrimientos de alta resistencia al tráfico

真正的木头



HYGIENIC
HIGIÉNICO
卫生的

Fiorwood's special antibacterial treatment guarantees the healthiness of the surface.

El tratamiento antibacteriano especial de Fiorwood garantiza la salubridad de la superficie.

Fiorwood的特殊抗菌处理保证了表面的健康



SAFE & STABLE
SEGURO Y ESTABLE
安全稳定

- Core is made by engineered 100% birch plywood FSC certified, with a finishing coat at the bottom of varnish for extra stability, moisture barrier and fire resistance..

- Underfloor heating suitable
- VOCs emission lower than 1000µg/m³: A+ Certification
- Fire ratings (following the norm EN 13501): Class C_{fl-s1}

- El núcleo está hecho de madera contrachapada 100% abedul con certificación FSC, y en la parte inferior tiene una capa de barniz para una mayor estabilidad, que actúa como barrera contra la humedad y aumenta su resistencia al fuego.

- Indicado para suelos radiantes.
- Emisión de VOC menor a 1000µg/m³: Certificación A+.
- Clasificación contra el fuego (siguiendo la norma EN 13501): Clase C_{fl-s1}

-核心由FSC工程胶合板制成, 底部涂有清漆, 具有额外的稳定性、防潮和防火性

- 适合地暖
- VOCs排放量低于1000 µ g/m³: A+认证
- 消防等级, 遵循规范EN 13501, 为Cf1-S1级



AFFORDABLE PRICE
PRECIO ACCESIBLE
实惠的价格

Thanks to the optimization of sources and the production process, Fiorwood® is an affordable price offering authentic REAL WOOD, aesthetically comparable to parquet

Gracias a la optimización de los recursos y al proceso de producción, Fiorwood® ofrece a un precio asequible MADERA REAL, estéticamente comparable al Parquet

由于对来源和生产工艺的优化, Fiorwood®价格实惠, 提供正宗的真木, 在美学上可与镶木地板相媲美。冰提供正宗的实木, 在美学上可与镶木地板相媲美



WHY FIORWOOD

POR QUÉ FIORWOOD?

为什么是Fiorwood?



ECO GREEN FLOORS
SUELOS ECOLÓGICOS
生态绿色地板

The philosophy of Fiorwood®, is based on offering quality products environmentally friendly, harvested from renewable forest sources and zero chemical emissions. Eco raw materials are optimized by using a thin top layer (0,6mm) of authentic wood species in order to create the maximum number of wood layers with the least waste of natural resources. As a supporter of environmentally friendly harvesting methods, Fiorwood® is FSC® certified.

La Filosofía de Fiorwood® está basada en ofrecer productos de calidad y respetuosos con el medio ambiente, con materia

proveniente de fuentes renovables y cero emisiones químicas. La fina capa de madera natural de 0,6mm de la parte superior, ayuda a optimizar la materia prima en modo ecológico, para así poder obtener el máximo número de capas de madera con el menor desperdicio de recursos naturales. Como defensor de la gestión de forma responsable de los bosques, Fiorwood® cuenta con la certificación FSC®

Fiorwood®的理念是基于提供优质环保产品，从可再生森林来源收获，零化学排放。通过使用天然木材物种的薄顶层（0.6毫米）来优化生态原材料，以创造最大数量的木材层，最大限度地减少自然资源的浪费。作为环保收获方法的支持者，Fiorwood®获得了FSC认证

ENVIRONMENTAL COMMITMENT

As a proponent of environmentally friendly harvesting methods, STP Wood Flooring is FSC certified (Forest Stewardship Council): C122157. Formaldehyde emission (EN 717-2): E1. STP formaldehyde emission is 97% lower than the maximum allowed: E1 (<3,5mg/h.m²)

Biological durability (EN 335-1 & 2): Class 1.

VOCs emission (ISO 16000-6:2006) <1000 g/m³: A+

Fiorwood offers the Traffic Brushed finish and, following the EN 685 regulation, has a level of use 23, for residential projects and level of use 32, with the same norm EN 685, for clients who plan on using floors in commercial areas

COMPROMISO MEDIOAMBIENTAL

Como defensor de los bosques gestionados de manera responsable, los suelos de madera STP tienen la certificación FSC (Forest Stewardship Council): C122157.

Emisión de formaldehído (EN 717-2): E1. La emisión de formaldehído STP es un 97% inferior al máximo permitido: E1 (<3,5mg/h.m²)

Durabilidad Biológica (EN 335-1 y 2): Clase 1.

Emisión de VOC (ISO 16000-6:2006) <1000 g/m³: A+

Fiorwood ofrece el acabado Traffic Brushed que, siguiendo la regulación EN 685, tiene un nivel de uso 23 para proyectos residenciales y nivel de uso 32 para áreas comerciales.

环境承诺

作为环保采伐方法的支持者，STP木地板通过了FSC认证（森林管理委员会）C122157。

Formaldehyde emission (EN 717-2) E1。STP甲醛排放量比允许的最大值低97%
生物耐久性（EN 335-1和2）第1类。



*FSC certified products available under request.

*Productos certificados FSC bajo pedido.

FSC 认证的产品可按需提供





LOCKSTEP®
EXCELLENT GLUELESS SYSTEM



Glueless System
Patent-protected worldwide



STRUCTURE

ESTRUCTURA

结构

FINISH: 12 coats of High Traffic varnish. Brushed open pore grain highlights the natural essence of the wood.

ACABADO: 12 capas de barniz de alto tráfico. El cepillado a poro abierto realza la esencia natural de la madera.

表面处理：12层抗裂清漆，开放性毛孔处理突显了木材的自然本质。



TOP LAYER: 0,6mm NOBLE WOOD micro-beveled.

CAPA SUPERIOR: 0,6 mm de MADERA NOBLE micro-biselada.

表层：0.6mm精选优质木材，微倒角。

CORE: 9 mm 100% birch plywood.

NÚCLEO: 9 mm de contrachapado fenólico 100% abedul.

基材：9mm 100%全桦木基材。

SUBSTRUCTURE: Contra-balance 0,6 mm Wood veneer with a finishing coat of varnish for extra stability and fire resistance.

SUBESTRUCTURA: Contra-cara de rechapado de madera de 0,6 mm con una capa de barniz final para una estabilidad y resistencia al fuego adicionales.

底层：0.6mm平衡实木，经过防水漆处理，以增加稳定性和防火性

SYSTEM

SISTEMA / 模块化系统

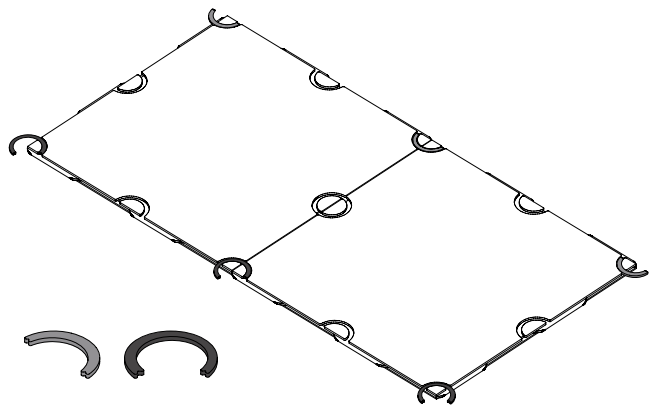

LockSTP is an innovative glueless flooring system which provides a precision interlocking bond between formats every time.

LockSTP es un innovador sistema de colocación en seco. Gracias a sus anclajes y a la precisión de su mecanizado se garantiza una unión perfecta sin necesidad de cola.

LOCKSTP地板锁扣是一样创新无胶地板系统，精准内锁环系统为地板提供了不需使用粘合剂的完美结合。

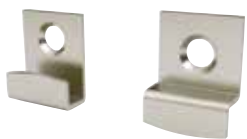

Covering hooks, for glueless wall applications.
Enganche de revestimiento, para la fijación de las piezas a pared sin necesidad de cola.
金属扣挂钩，用于无胶的墙面安装。



Union rings for joint pieces. * White ring for use only in Chevron, Diamond and Hexagon installation.
Anillas para la unión de piezas. * La anilla blanca solamente se utiliza para la instalación de Chevron, Diamond y Hexagon.
三种环形锁扣。白色地板扣仅用于鱼骨拼及异形款式地板的安装。

¹Colors out of catalogue, species, herringbone and formats with transversal grain are also available upon request (Minimum order of 200 sqm per color). ²Color & tone may vary from plank to plank due to reactive stain and/or treated veneer. ³Lacquered colors, then it will be resistant to moderate traffic, instead of high traffic. ⁴ Wood is a natural product and contains variations in grain, mineral streaks and knots that may not be represented by these images. Lighting, camera settings and printer configurations may also affect the colors represented in these photos. Please review samples and consult a sales specialist before placing orders.

¹Colores fuera de catálogo, otras especies de madera, mecanizado herringbone y formatos con malla transversal disponibles bajo pedido (mínimo 200 m2 por color). ² El color y el tono puede variar entre las piezas debido al tinte reactivo o al tratamiento del rechapado. ³ Los colores lacados son resistentes al tráfico moderado (no al tráfico alto). ⁴ La madera es un producto natural que contiene variaciones en la malla, vetas y nudos que pueden no estar representados en estas imágenes. La iluminación, la configuración de la cámara y la impresión también pueden afectar a los colores representados. Por favor, compruebe las muestras y consulte con el departamento de ventas antes de realizar pedidos.

EUROPEAN WHITE OAK (100% Wood Veneer, Oak)¹



DELUX OAK (100% Wood Veneer, Oak)¹

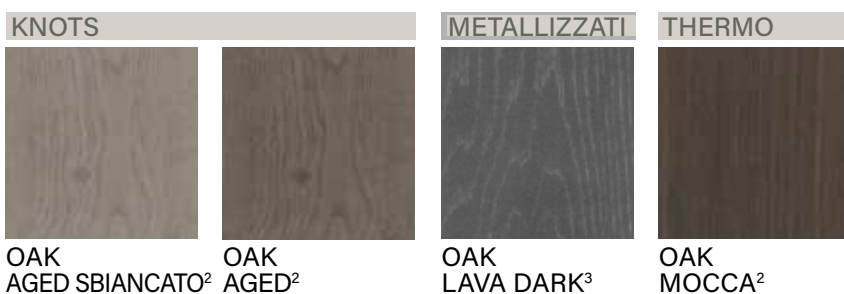

COLORS

COLORES / 颜色

1其他颜色、物种、人字形和横向纹理的格式也可根据要求提供（每种颜色最低订购量为200平方米）。2由于反应性污渍和/或经过处理的贴面，颜色和色调可能因木板而异。3漆色，那么它将抵抗适度的交通，而不是高交通。4Wood是一种天然产品，含有这些图像可能无法代表的谷物、矿物条纹和结的变化。照明、相机设置和打印机配置也可能影响这些照片中显示的颜色。在下订单之前，请查看样品并咨询销售专家。

TINTE UNITE OAK (100% Wood Veneer, Oak)¹



OAK
CHERRY³



OAK
EXTRA WHITE³



OAK GRIGIO
CEMENTO³



OAK GRIGIO
PERLA



OAK
INDIGO



OAK MENTHA³



OAK
TORTORA³



OAK
TURQUOISE³

AMERICAN WALNUT (100% Wood Veneer, American Walnut)



A. WALNUT
ASH



A. WALNUT
HONEY



A. WALNUT
LIGHT

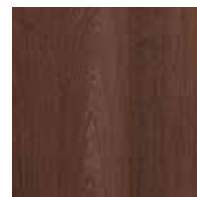

A. WALNUT
NATURAL



A. WALNUT
SBIANCATO



EXOTIC
IROKO

EXOTIC¹



FORMATOS / 尺寸及样式

SIZES

Fior+

Fior Tavole

Fior Chevron

Fior Design

Fior Premium

Fior⁺

UPON REQUEST, FORMATS ARE ALSO AVAILABLE WITH TRANSVERSAL GRAIN /
Formatos también disponibles con malla transversal bajo pedido / 如有需求，可以定制横向纹理



290x290
11,42"x11,42"



580x290
22,83"x11,42"



580x580
22,83"x22,83"



870x290
34,25"x11,42"



1160x290
45,67"x11,42"



1160x580
45,67"x22,83"

FiorTavole[®]

* HERRINGBONE ENGINEERING AVAILABLE UPON REQUEST / Mecanizado Herringbone disponible bajo pedido / 可以定制人字拼



580x145
22,83"x5,71"



870x145
34,25"x5,71"



1160x145
45,67"x5,71"



1160x195
45,67"x7,68"



2320x145
91,34"x5,71"



2320x195
91,34"x7,68"

TAVOLE FIOR, ENGINEERED WITH TRADITIONAL TONGUES & GROOVES SYSTEM FOR GLUE DOWN INSTALLATION. POSSIBILITY OF FIOR LISTONE WITH LOCKSTP SYSTEM DEPENDING ON THE PROJECT / Tavole Fior, mecanizada con el sistema tradicional de macho&hembra para instalación encolada. Puede haber posibilidad de Listone Fior con sistema LockStp según el proyecto. / TAVOLE FIOR, 采用传统的舌头和凹槽系统设计，用于粘合安装。带有LOCKST系统的FIOR LISTONE的可能性取决于项目带有LOCKST系统的FIOR LISTONE，具体取决于项目

FiorChevron[®]

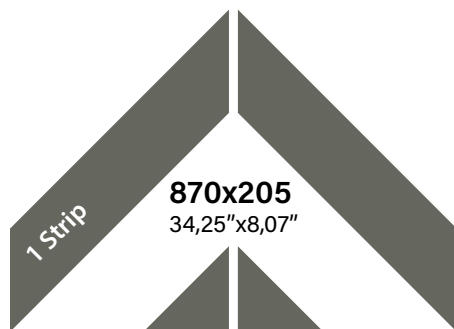

870x205
34,25"x8,07"



580x205
22,83"x8,07"

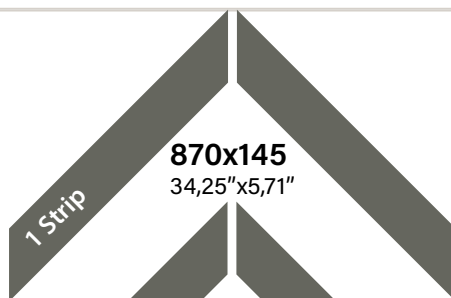

870x145
34,25"x5,71"



580x145
22,83"x5,71"



410x145
16,14"x5,71"

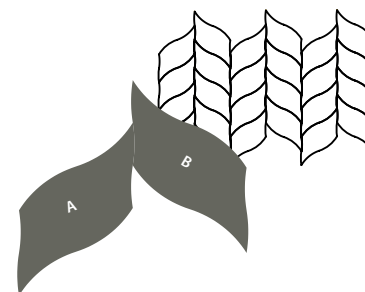

CHEVRON FIORE
502x205
19,76"x8,07"

FIOR DESIGN®

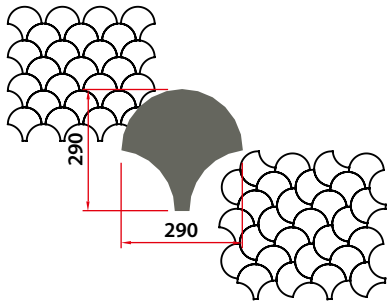

SQUAMA
290x290
11,42"x11,42"

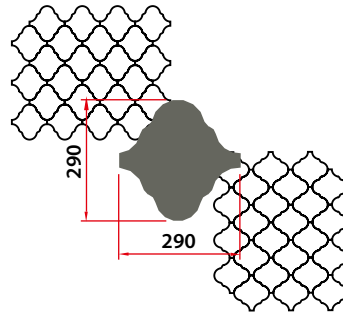

MORISCO
290x290
11,42"x11,42"

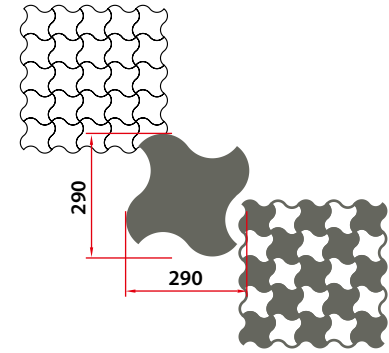

SHURIKEN
290x290
11,42"x11,42"

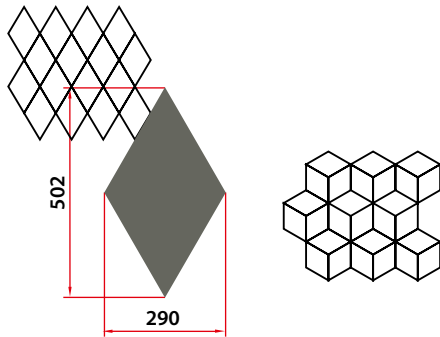

DIAMOND
502x290
19,76"x11,42"

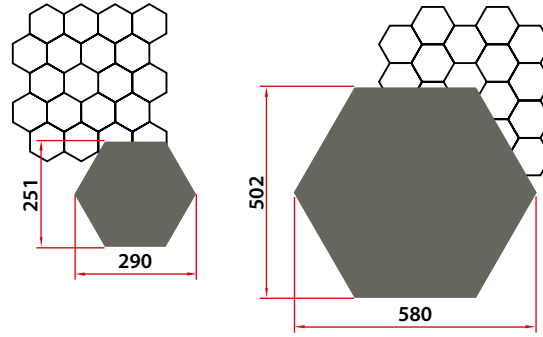

HEXAGON 290 **& HEXAGON 580**
290x251 **580x502**
11,42"x9,88" 22,83"x19,76"

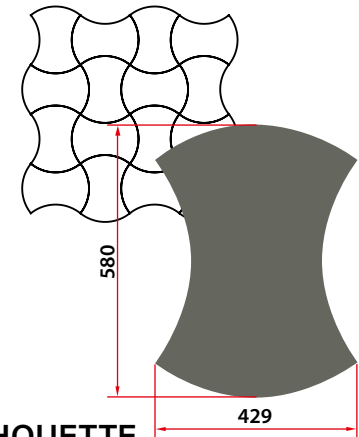

SILHOUETTE
580x429
22,83"x16,90"

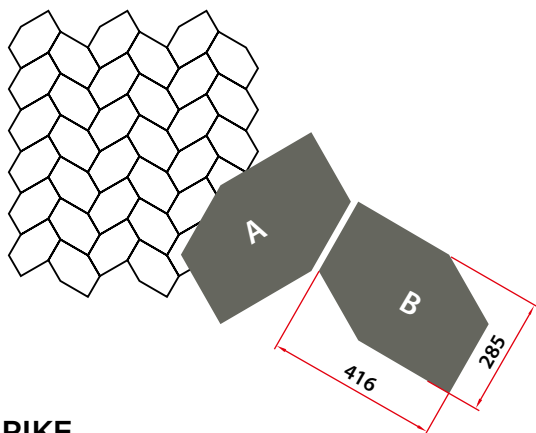

SPIKE
416x285
16,38"x11,22"

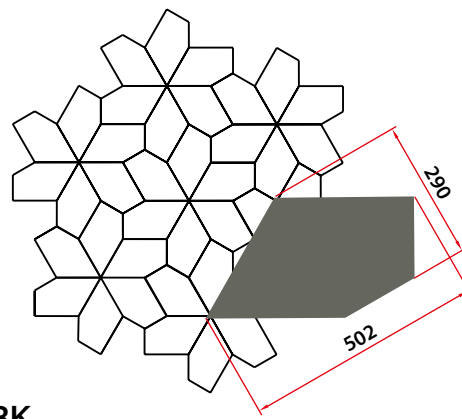

SPARK
502x290
19,76"x11,42"

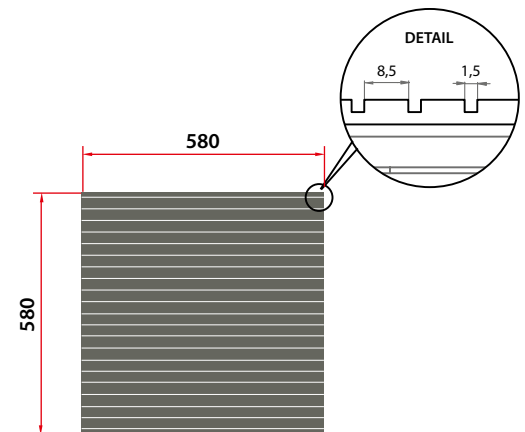

MULTI-RIGATO
580x580
22,83"x22,83"

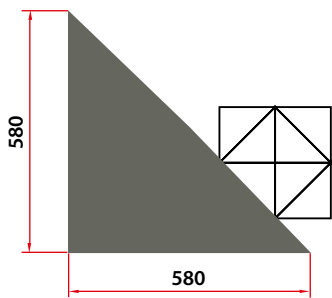

TRIANGLE
580x580
22,83"x22,83"

TRG-A		TRG-A		TRG-C		TRG-E		
Format	TRIANGLE 580x580	Format	TRIANGLE 580x580	Format	TRIANGLE 580x580	Format	Triangle 580x580	580x580
% m ²	100% (50% of each color)	% m ²	100% (50% of each color)	% m ²	100% (50% of each color)	% m ²	50%(25% of each color)	50%

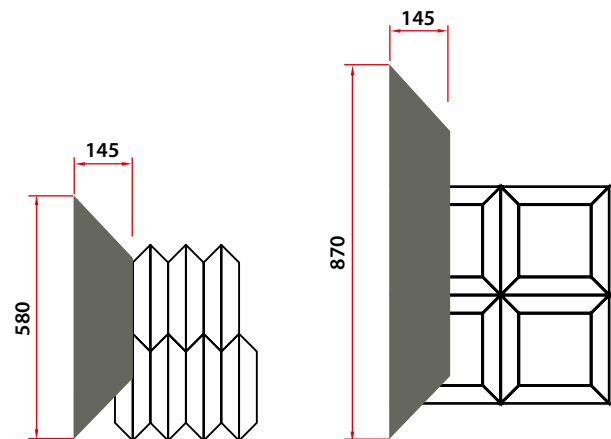

TRAPEZIUM 580 & **TRAPEZIUM 870**
580x145 & **870x145**
22,83"x5,71" & 34,25"x5,71"

TRP-B		TRP-D			TRP-C			
Format	870x145 - 580x145	Format	870x145	290x290	870x870	Format	870x145	Triangle 580x580
% m ²	100 %	% m ²	28 %	22 %	50 %	% m ²	56 %	44 %

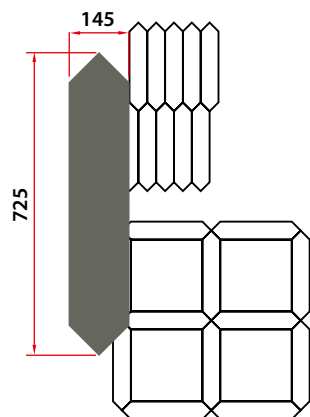

ARROW
725x145
28,54"x5,71"

ARW-B			ARW-B		
Format	725x145	290x290	Format	725x145	580x290
% m ²	36 %	64 %	% m ²	36 %	64 %

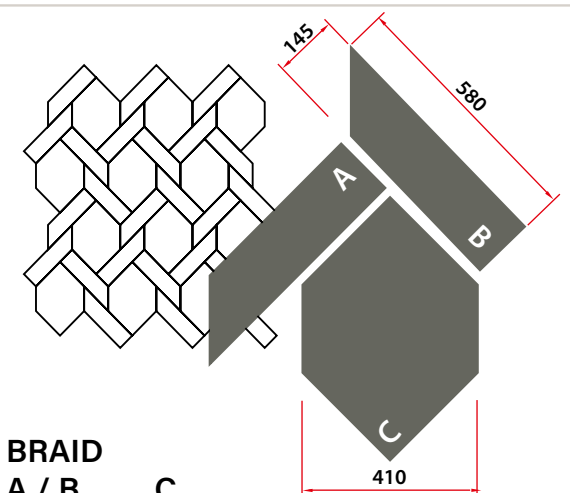

BRAID
A / B & **C**
580X145 & **615X410**
22,83"x5,71" & 24,21"x16,14"

RHOMBUS
1160x290
 45,67"x11,42"

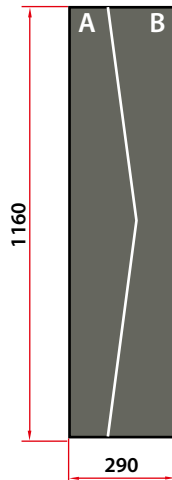

RHM-A		RHM-B		RHM-C		RHM-D	
Format	RHOMBUS 1160x290	Format	RHOMBUS 1160x290	Format	RHOMBUS 1160x290	Format	RHOMBUS 1160x290
% m ²	100%	% m ²	100%	% m ²	100%	% m ²	100%



- * 8 different pieces. STANDARD: Regular bevel.
- * 8 piezas distintas. ESTÁNDAR: Bisel regular.
- * 八个不同的木块：标准、常规倒角、

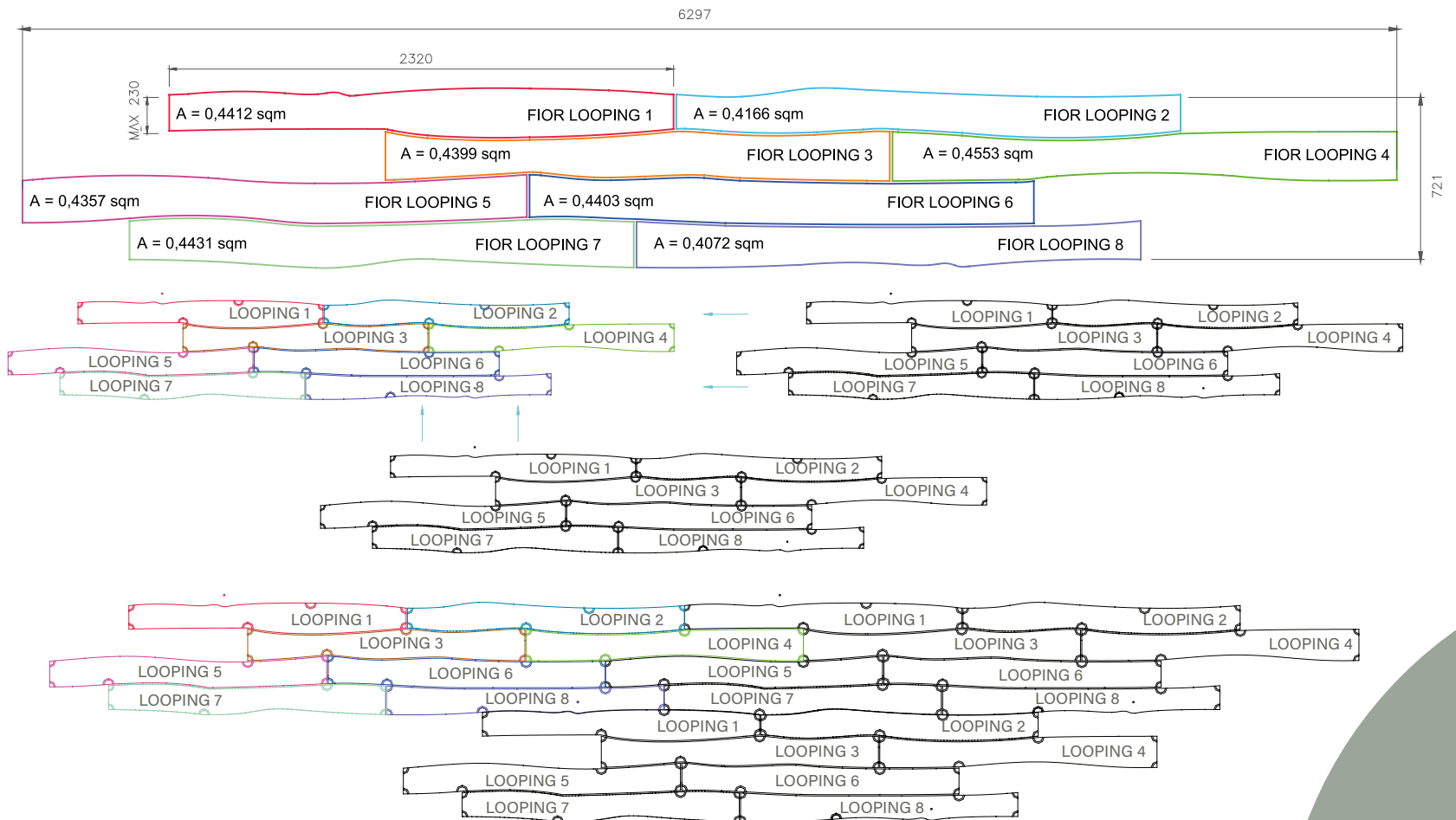

AV

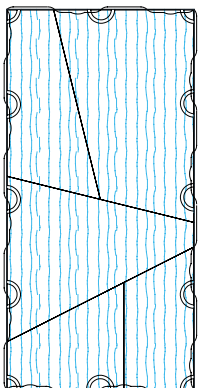

BV

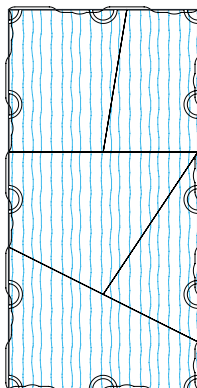

CV

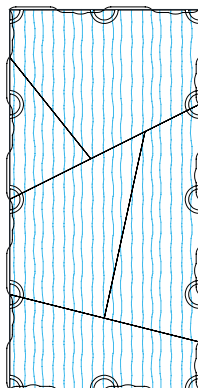

AH

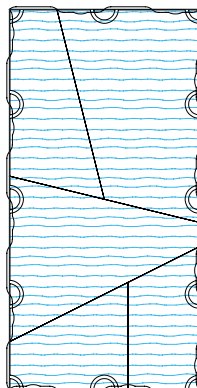

BH

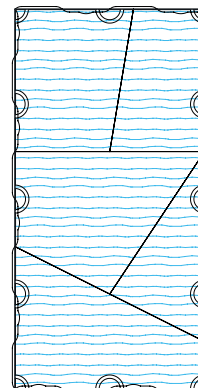

CH

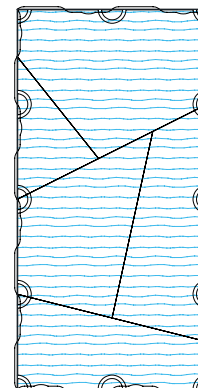

TRENCADIS - VERTICAL

3 different designs but with the same vertical grain direction for each full piece
 3 Diseños diferentes con la malla en dirección vertical
 3种不同的设计，但每个完整的TRENCADIS具有相同的垂直晶粒方向-水平

TRENCADIS - HORIZONTAL

3 different designs but with the same horizontal grain direction for each full piece
 3 Diseños diferentes con la malla en dirección horizontal
 3种不同的设计，但每整件具有相同的水平晶粒方向

TRENCADIS

1160x580 - 45,67"x22,83"

ASSEMBLY SCHEME / ESQUEMA DE MONTAJE / 装配图

TRN-A		TRN-B		TRN-C	
Format	1160 x580	Format	1160 x580	Format	1160 x580
% m ²	100 %	% m ²	100 %	% m ²	100 %
TRN-D		TRN-E		TRN-F*	
Format	1160 x580	Format	1160 x580	Format	1160 x580
% m ²	100 %	% m ²	100 %	% m ²	100 %
				*Most recommended pattern	

Premium¹⁶

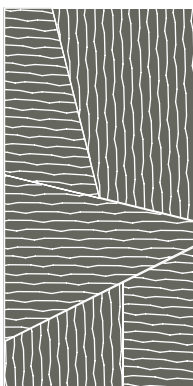

TRENCADIS PREMIUM 16

3 different designs composed of 5 different portions of 0,6mm noble wood, plus 9mm of 100% birch plywood with different grain direction, all of them assembled on a 6mm plywood base. Then, for each design there are two different variations, Horizontal and Vertical. 16mm nominal thickness

3 diseños diferentes compuestos por cinco piezas distintas de 0,6mm de madera noble más 9mm de 100% madera chapada con la malla en diferentes direcciones. Todo ello ensamblado en una base de madera chapada de 6mm. Así pues, para cada diseño están disponibles las dos variantes: horizontal y vertical.

Espesor nominal: 16mm

**TRENCADIS
PREMIUM 16**
1160x580
45,67"x22,83"

3种不同的设计，由5个不同部分的0.6毫米高贵木材加上9毫米的100%桦木胶合板组成，具有不同的纹理方向，所有这些都组装在6毫米的胶合板底座上。然后，对于每个设计，两种不同的变化，水平和垂直。16毫米标称厚度。

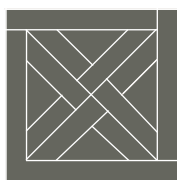

VERSAILLES PREMIUM 16

Palace design composed of the different portions of 0,6mm noble wood plus 9mm of 100% birch plywood with different grain direction, all of them assembled on a 6mm plywood base. 16mm nominal thickness.

Palace Design, compuesto por diferentes piezas de 0,6mm de madera noble más 9mm de 100% madera chapada con la malla en diferentes direcciones. Todo ello ensamblado en una base de madera chapada de 6mm.

Espesor nominal: 16mm

**VERSAILLES
PREMIUM 16**
580x580
22,83"x22,83"

宫殿设计由0.6毫米高贵木材的不同部分加上9毫米不同纹理方向的100%桦木胶合板组成，所有这些都组装在6毫米的胶合板底座上。标称厚度为16毫米。

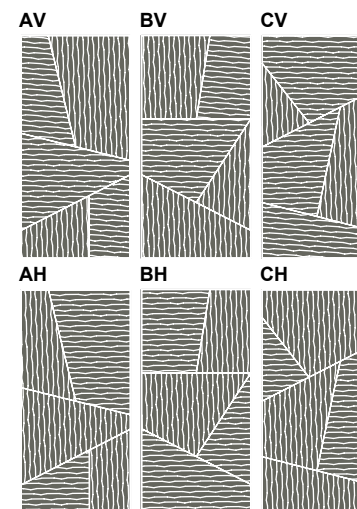

PREMIUM16 STRUCTURE / COMPOSICION / 组成

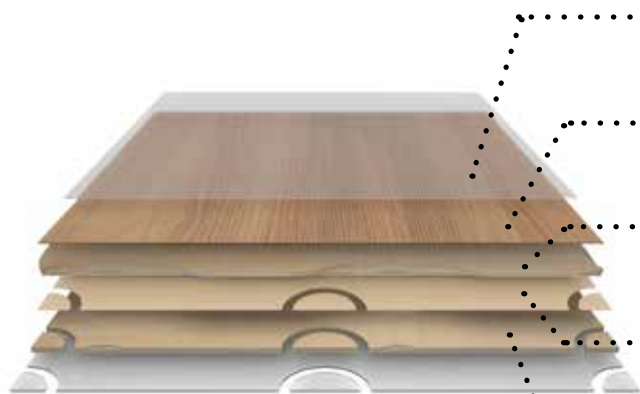

FINISH. 12 coats of High Traffic varnish. Brushed open pore grain highlights the natural essence of the wood.

ACABADO: 12 capas de barniz que soportan un alto tráfico. La veta de poro abierto cepillada resalta la esencia natural de la madera.

完成。12层高流量清漆。拉丝开孔纹理突出了木材的自然本质。

TOP LAYER. 0,6 mm NOBLE WOOD, micro-bevelled

CAPA SUPERIOR: 0,6mm DE MADERA NOBLE, MICROBISELADA

顶层。0.6毫米高贵木材，微斜面芯。

CORE. 9 mm 100% birch plywood.

NÚCLEO: 9 mm de fenólico contrachapado 100% abedul.

9毫米100%桦木胶合板。

SUBSTRUCTURE. Contra-balance 0,6 mm Wood veneer with a finishing coat of varnish for extra stability and fire resistance.

SUBESTRUCTURA: Contra-cara de chapado de madera de 0,6 mm con una capa de barniz final para una estabilidad adicional y resistencia al fuego.

子结构。对比平衡0.6毫米木质贴面，饰有清漆，具有额外的稳定性和耐火性。

BASE. 6 mm 100% birch plywood.

BASE: 6 mm de fenólico contrachapado 100% abedul.

底座。6毫米100%桦木胶合板。

MOUNTING SCHEMES

ESQUEMAS DE MONTAJE / 安装方案

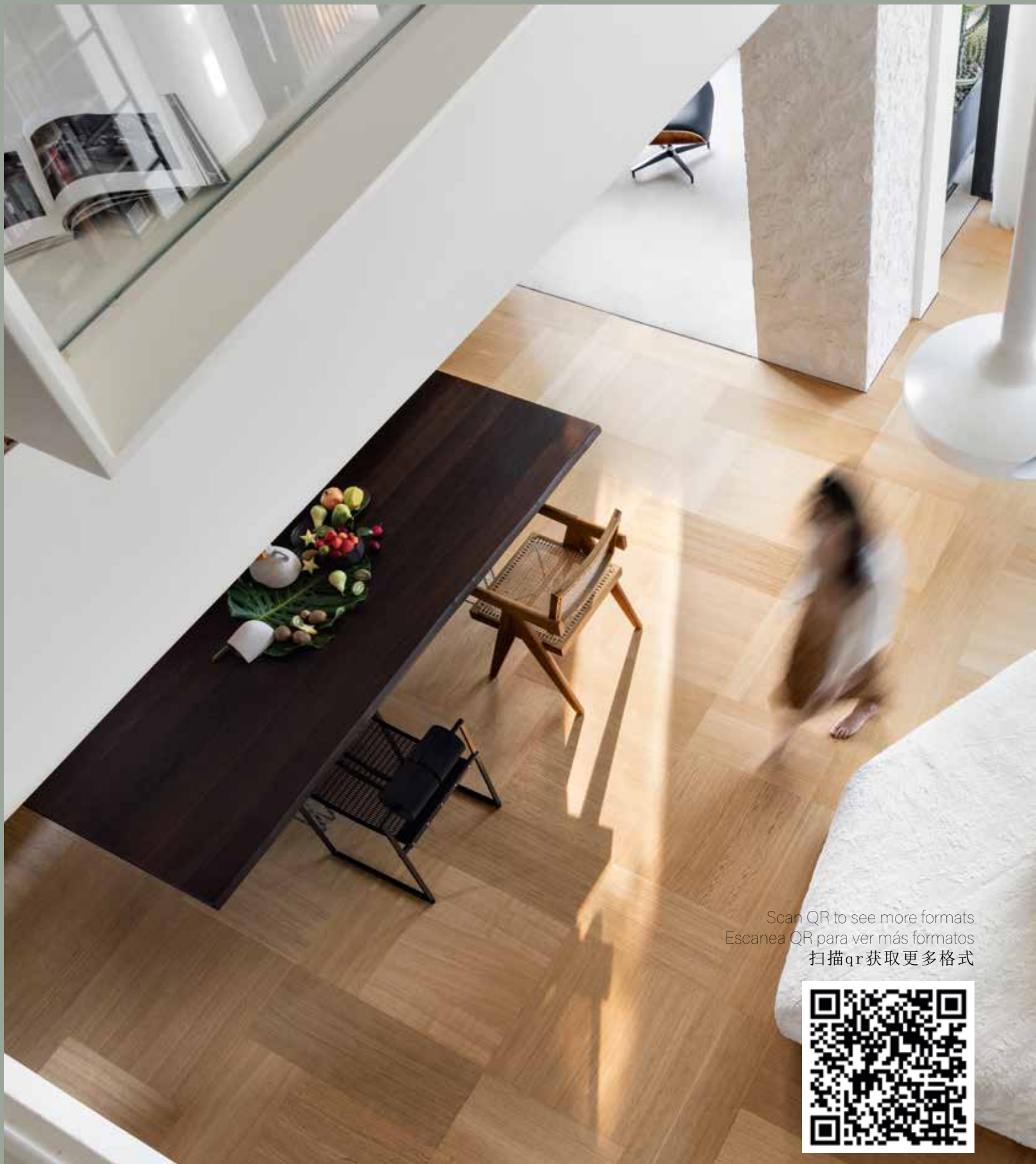

Scan QR to see more formats
Escanea QR para ver más formatos
扫描qr获取更多格式



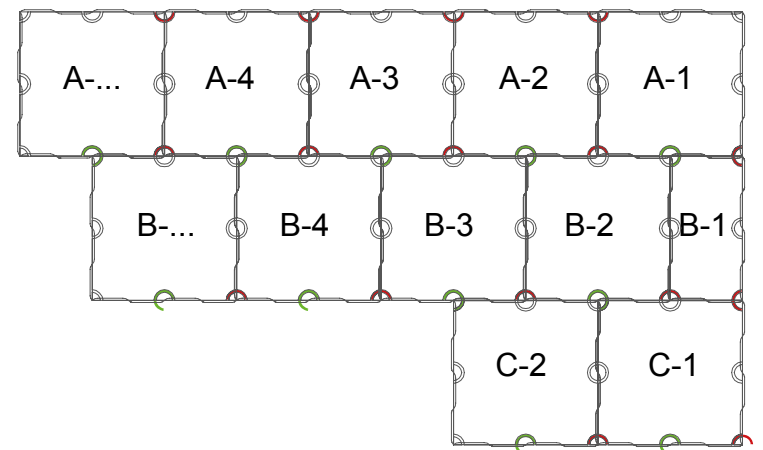
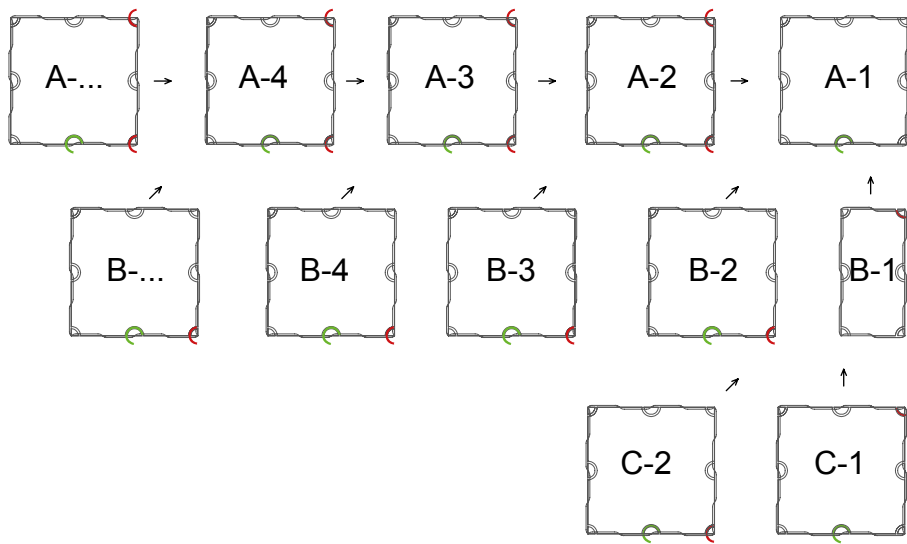
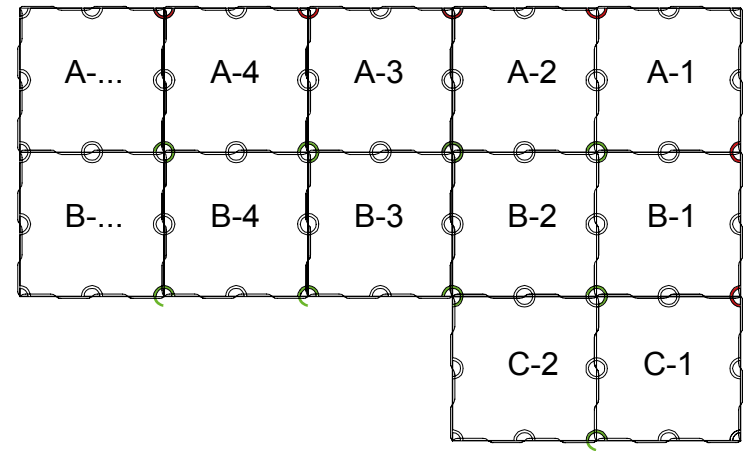
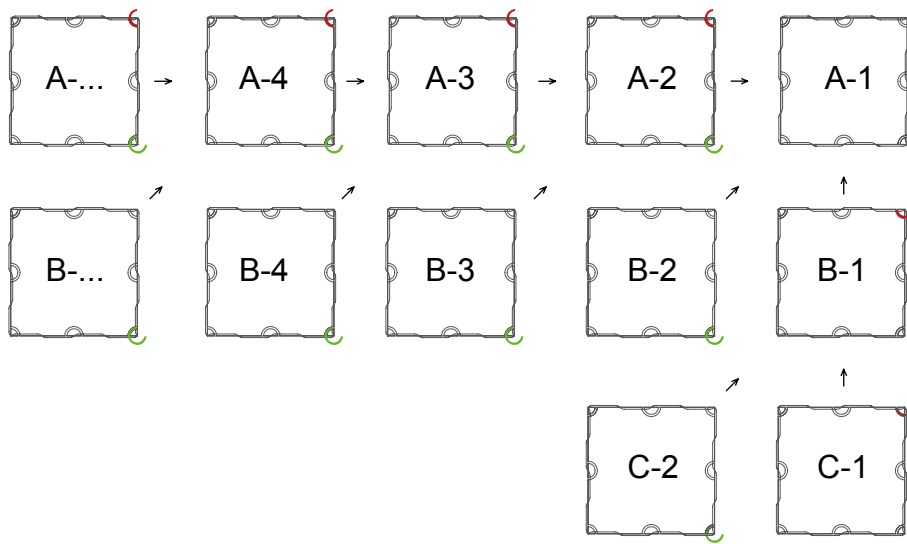

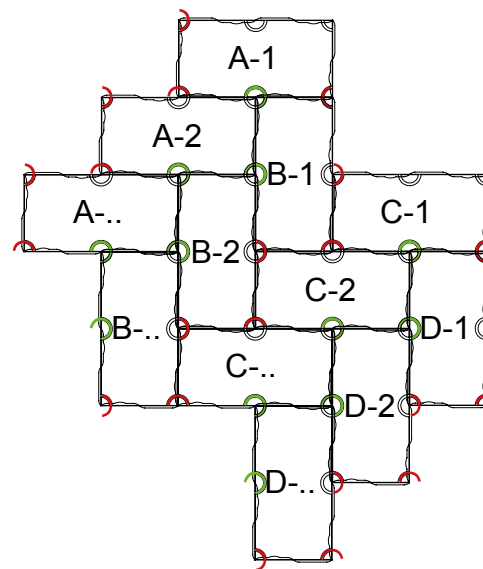
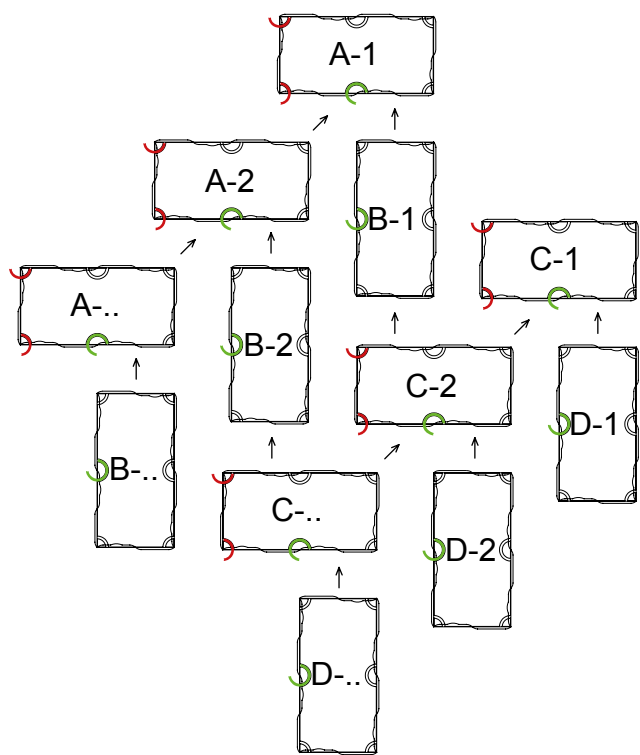
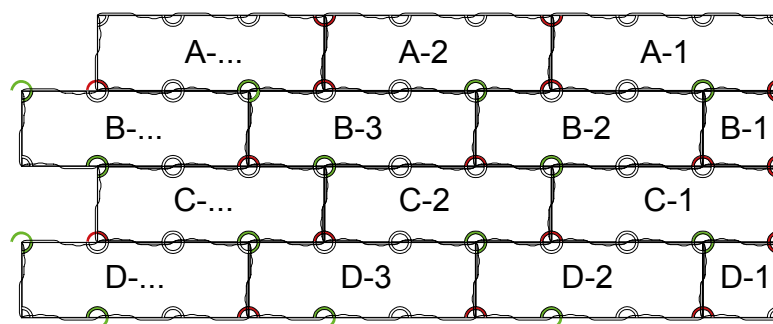
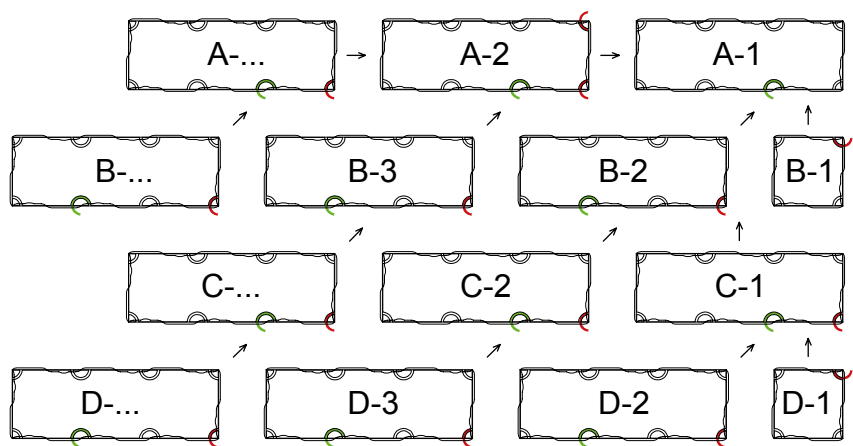

U MOUNTING SCHEME / ESQUEMA DE MONTAJE U/ U直拼

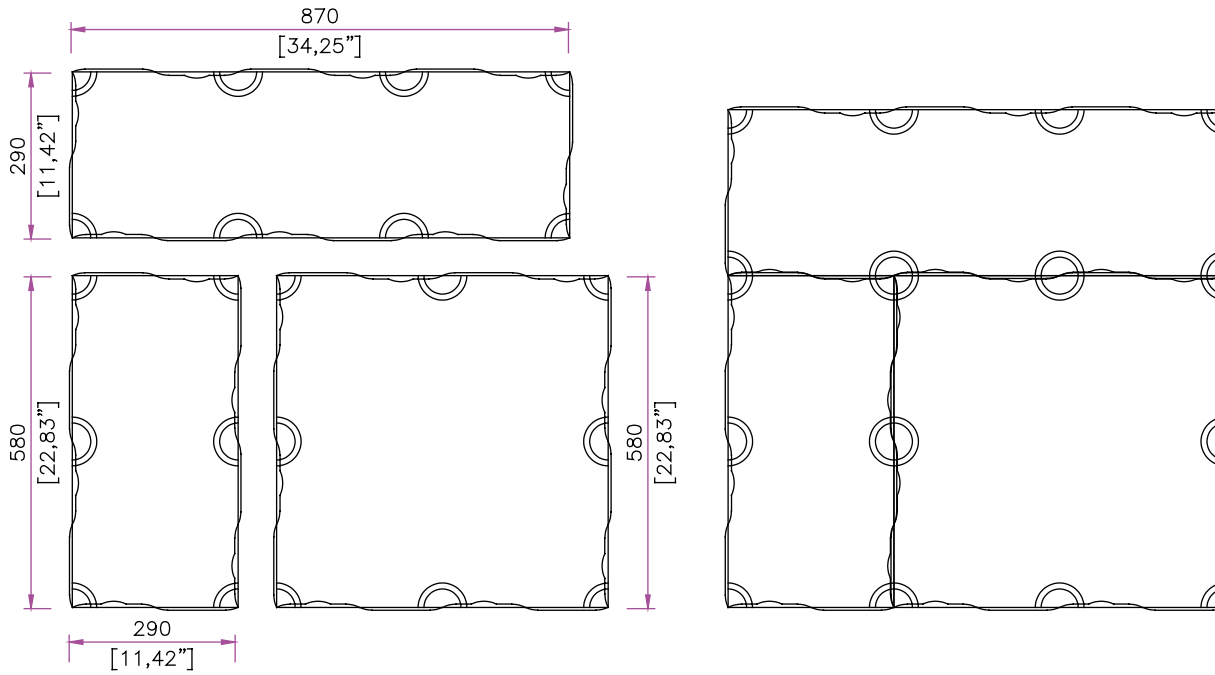

U1				U2				U3				U4			
Format	580x580	870x290	580x290	Format	580x580	870x290	580x290	Format	580x580	870x290	580x290	Format	580x580	870x290	580x290
% m ²	44.45 %	33.33 %	22.22 %	% m ²	44.45 %	33.33 %	22.22 %	% m ²	44.45 %	33.33 %	22.22 %	% m ²	44.45 %	33.33 %	22.22 %

U5				U6				U7				U8			
Format	580x580	870x290	580x290	Format	580x580	870x290	580x290	Format	580x580	870x290	580x290	Format	580x580	870x290	580x290
% m ²	44.45 %	33.33 %	22.22 %	% m ²	44.45 %	33.33 %	22.22 %	% m ²	44.45 %	33.33 %	22.22 %	% m ²	44.45 %	33.33 %	22.22 %

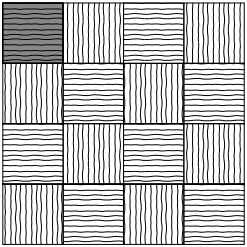
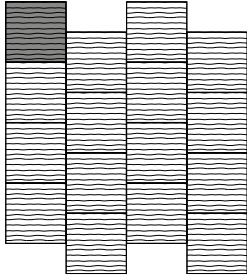
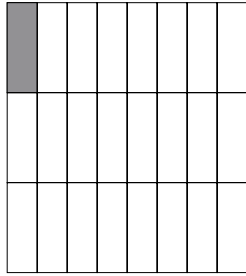
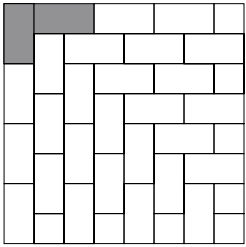
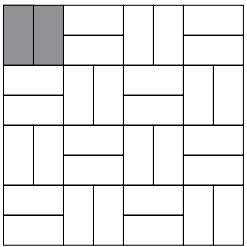
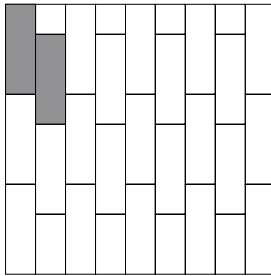
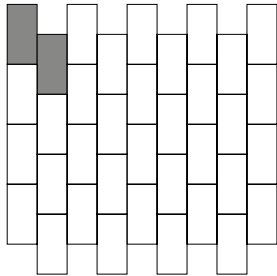
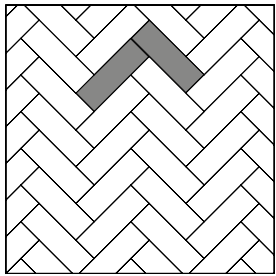
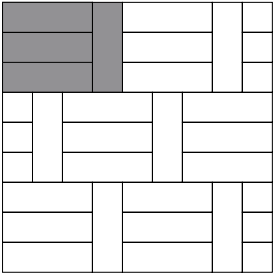
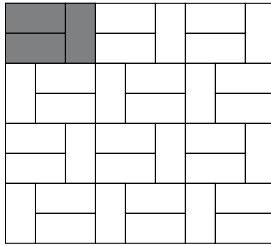
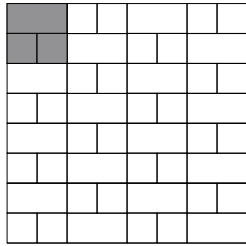
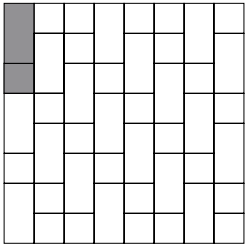
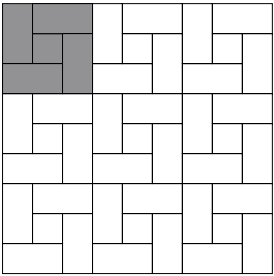
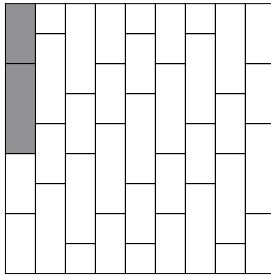
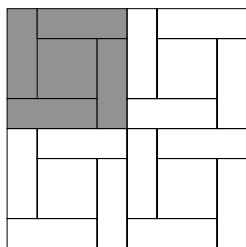
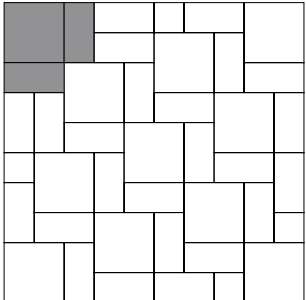
A		B		C		E	
Format	290x290 - 580x580	Format	290x290 - 580x580	Format	580x290 - 870x290 1160x290 - 1160x580	Format	580x290 - 870x290 1160x290 - 1160x580
% m ²	100 %	% m ²	100 %	% m ²	100 %	% m ²	100 %
							
F		G		I		H	
Format	580x290 - 1160x580	Format	870x290 - 1160x290 - 1160x580	Format	580x290 - 1160x290 - 1160x580	Format	580x290 - 870x290 1160x290 - 1160x580
% m ²	100 %	% m ²	100 %	% m ²	100 %	% m ²	100 %
							
J		K		M		Q	
Format	870x290	Format	580x290 - 1160x580	Format	580x290 - 1160x580 290x290 - 580x580	Format	580x290 - 1160x580 290x290 - 580x580
% m ²	100 %	% m ²	100 %	% m ²	50 %	50 %	66.67 % 33.33 %
							
L		R		N		O	
Format	580x290 - 1160x580 290x290 - 580x580	Format	870x290 580x290	Format	580x580 870x290	Format	580x580 580x290
% m ²	88.89 % 11.11 %	% m ²	60 % 40 %	% m ²	25 % 75 %	% m ²	50 % 50 %
							

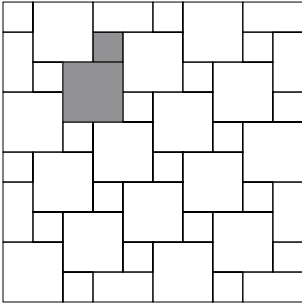
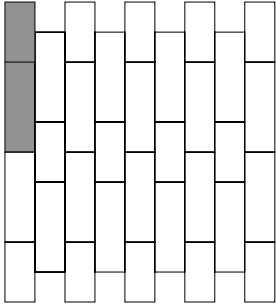
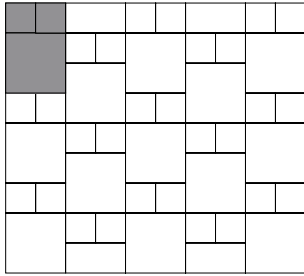
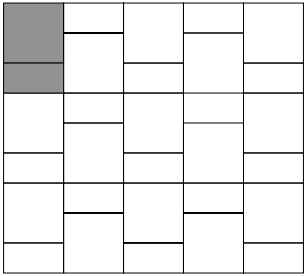
P			S			T			V		
Format	580x580	290x290	Format	870x290 - 1160x290	580x290 - 870x290	Format	580x580	290x290	Format	580x580	580x290
% m ²	80 %	20 %	% m ²	60 % - 57.15 %	40 % - 42.85 %	% m ²	66.67 %	33.33 %	% m ²	66.67 %	33.33 %
											

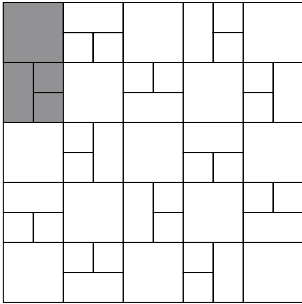
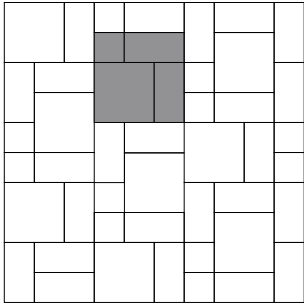
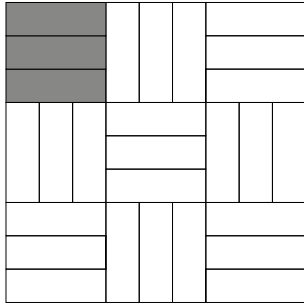
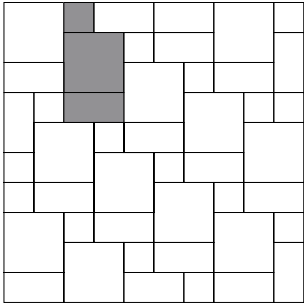
W				AB				X		Y			
Format	580x580	580x290	290x290	Format	580x580	580x290	290x290	Format	870x290	Format	580x580	580x290	290x290
% m ²	50 %	25 %	25 %	% m ²	44.44 %	44.44 %	11.11 %	% m ²	100 %	% m ²	57.14 %	28.57 %	14.29 %
													

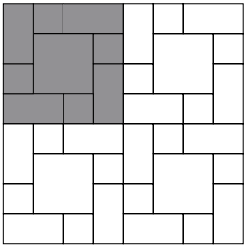
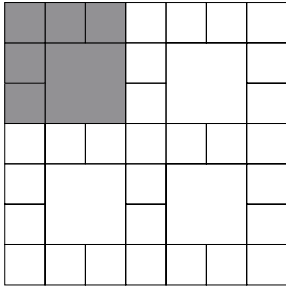
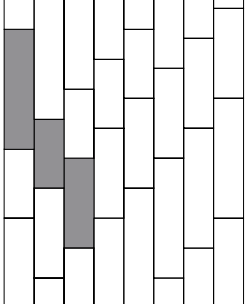
AC				Z				AD			AG			
Format	580x580	580x290	290x290	Format	580x580	580x290	290x290	Format	580x580	290x290	Format	1160x290	870x290	580x290
% m ²	25 %	50 %	25 %	% m ²	44.44 %	44.44 %	11.11 %	% m ²	44.44 %	55.56 %	% m ²	44.44 %	33.33 %	22.22 %
														



FIORWOOD+ 1160x290 - 870x290 - 580x290 VERSATILITY/ VERSATILIDAD FIORWOOD+ 1160x290 - 870x290 - 580x290/
 FIORWOOD+ 1160x290 - 870x290 - 580x290 多功能性

VERSATILE FORMATS, CAN BE LAID AS:

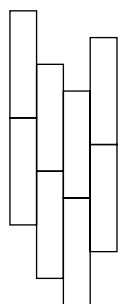

STRAIGHT PLANKS

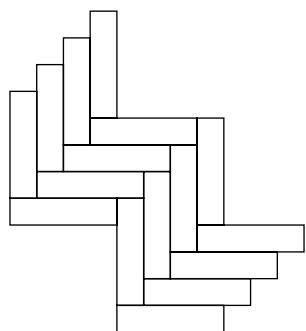

HERRINGBONE

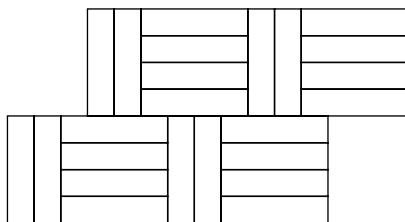

DIFFERENT FORMATS

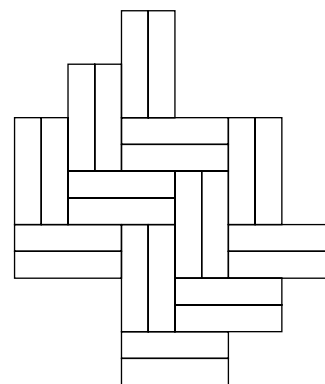

DOUBLE HERRINGBONE

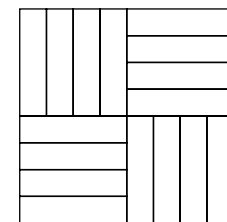

SQUARE

Format	AF	H	AJ	AK	X
Format	1160x290	Format	1160x290	Format	1160x290

Format	AF	H	J	AK	X
Format	870x290	Format	870x290	Format	870x290

Format	I	H	K	E	F
Format	580x290	Format	580x290	Format	580x290

CHEVRON

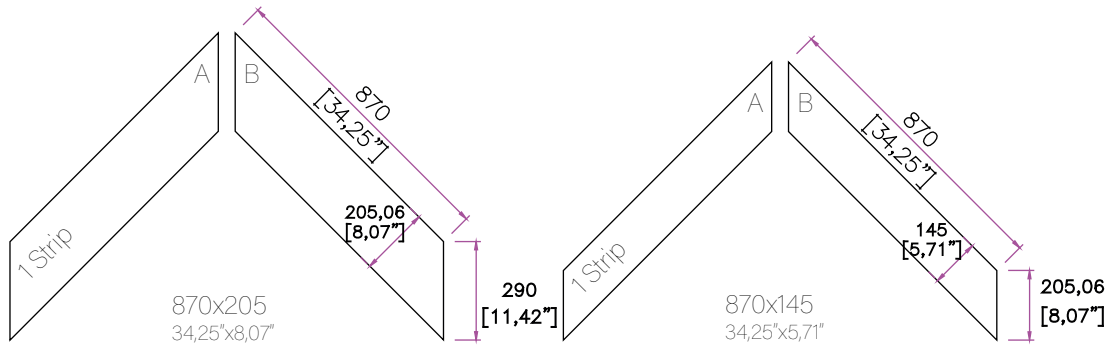

*Chevron series is only available in 1 Strip
Serie Chevron sólo disponible con 1 lama
*雪佛龙系列仅提供1条

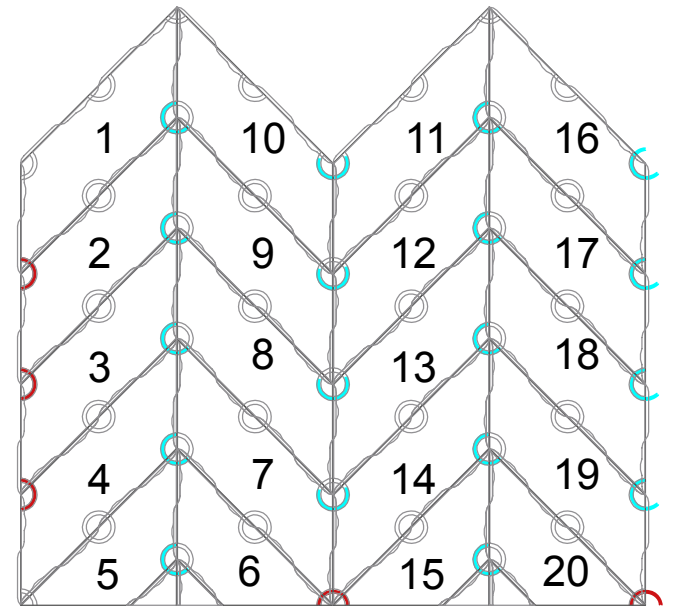
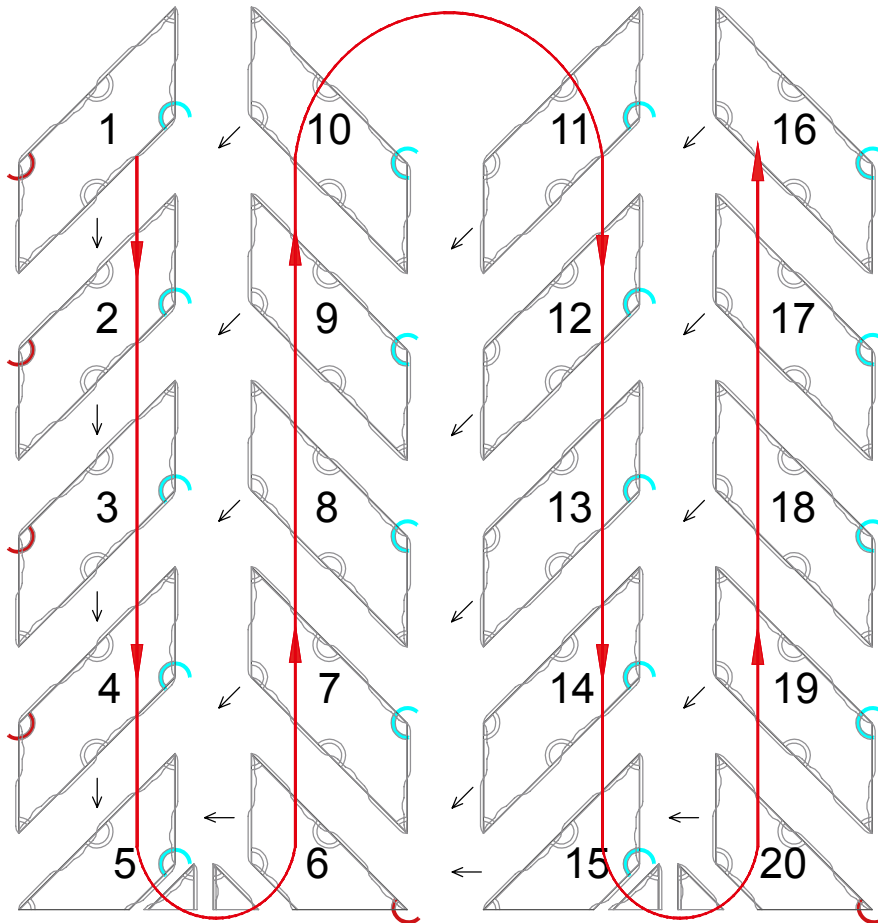
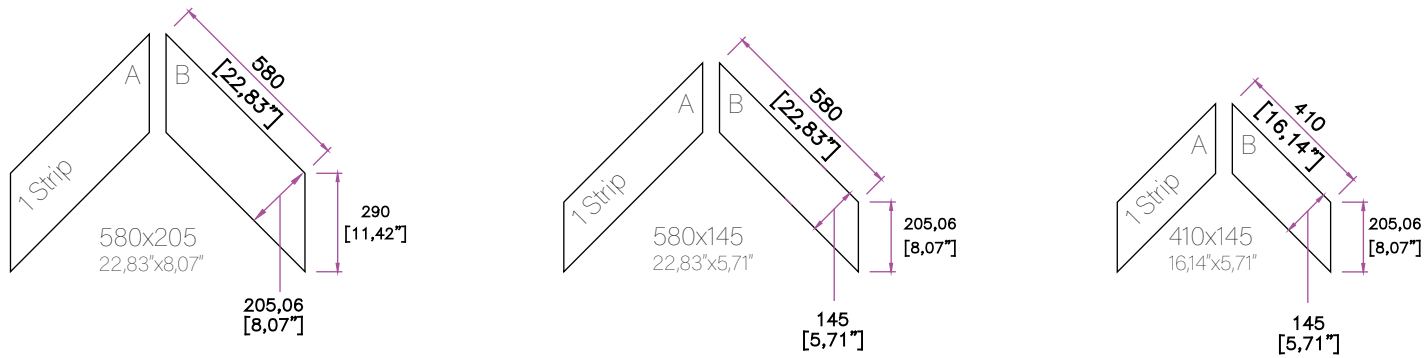

CHV-A			CHV-B			CHV-C			CHV-J						
Format	870x205A - 580x205A- 870x145A - 580x145A	870x205B - 580x205B- 870x145B - 580x145B	Format	580x205A	580x205B	Format	870x205A - 580x205A- 870x145A - 580x145A	870x205B - 580x205B- 870x145B - 580x145B	Format	870x205A - 580x205A-870x145A - 580x145A	870x205B - 580x205B- 870x145B - 580x145B				
% m ²	50 %	50 %	% m ²	50 %	50 %	% m ²	50 %	50 %	% m ²	67 %	33 %				
CHV-E			CHV-F			CHV-G			CHV-D						
Format	870x205A - 580x205A- 870x145A - 580x145A	870x205B - 580x205B- 870x145B - 580x145B	Format	580x580	580x205A 580x145A	580x205B 580x145B	Format	870x290	870/580x205A 870/580x145A	870/580x205B 870/580x145B	Format	580x580	290x290	580x205A	580x205B
% m ²	50 %	50 %	% m ²	58%(205)- 66%(145)	21%(205)- 17%(145)	21%(205)- 17%(145)	% m ²	42%(205)- 50%(145)	29%(205)- 25%(145)	29%(205)- 25%(145)	% m ²	51 %	13 %	18 %	18 %

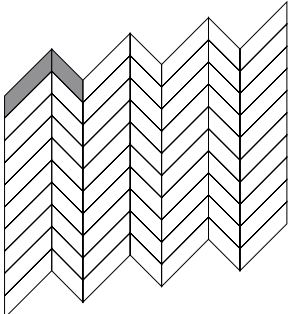
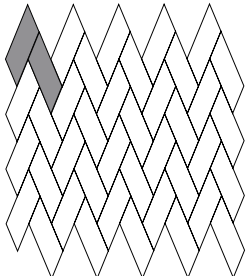
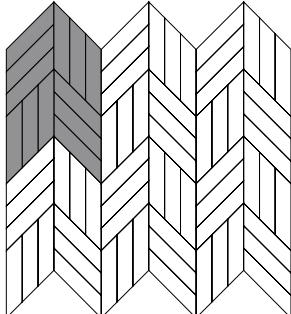
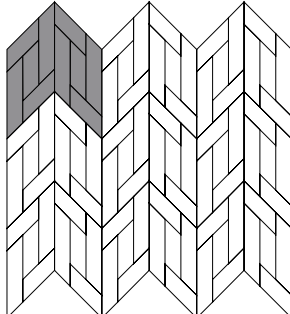
CHV-I			CHV-K1			CHV-L			CHV-Q				
Format	870x205A - 870x145A	580x205B - 580x145B	Format	870/580x205A 410x145A	870/580x205B 410x145B	Format	870x205A	870x205B	Format	870x205A	870x205B	580x205A	580x205B
% m ²	60 %	40 %	% m ²	50 %	50 %	% m ²	50 %	50 %	% m ²	25 %	25 %	25 %	25 %
													

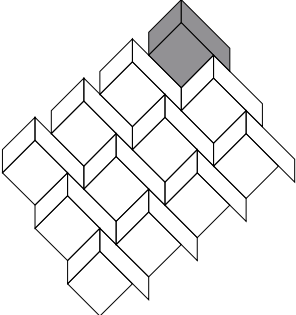
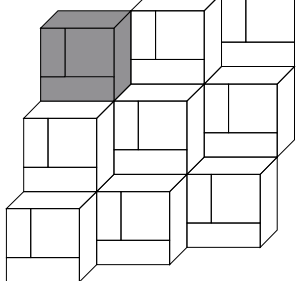
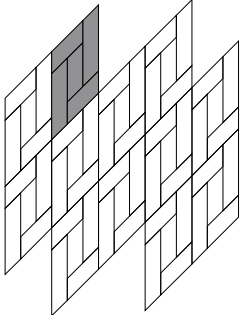
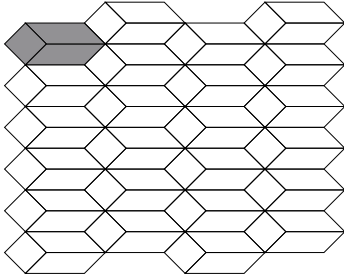
CHV-M				CHV-N					CHV-P				CHV-O				
Format	580x580	580x205A 580x145A	870x205B 870x145B	Format	580x580	580x290	870x290	870x205A	870x205B	Format	580x580	580x205A 580x145A	870x205B 870x145B	Format	290x290	580x205A 870x205A	580x205B 870x205B
% m ²	53%(205) 62%(145)	19%(205) 15%(145)	28%(205) 23%(145)	% m ²	30 %	15 %	23 %	16 %	16 %	% m ²	33 %	17 %	50 %	% m ²	26%(580)- 20%(870)	37%(580)- 40%(870)	37%(580)- 40%(870)
																	



Chevron 580x145
Tavole 2320x145
Oak Cognac

ACCESSORIES

ACCESORIOS / 配件

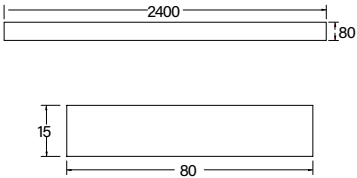
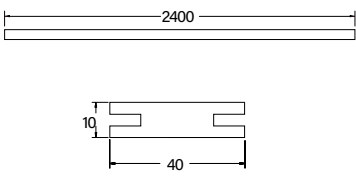
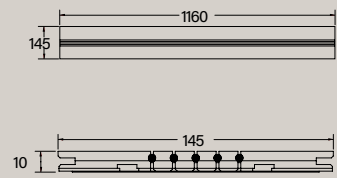
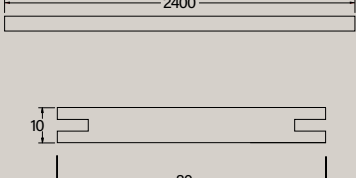
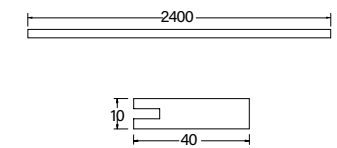
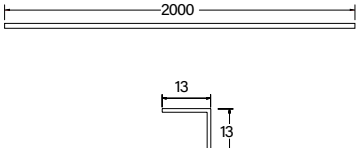
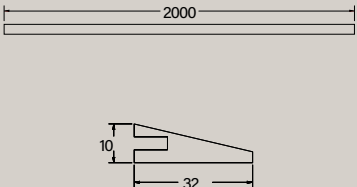
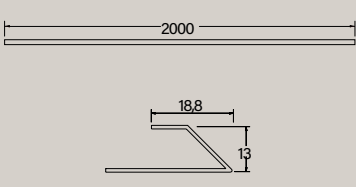
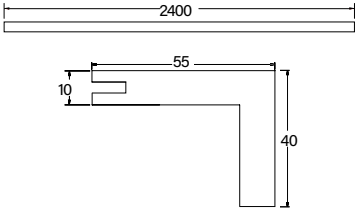
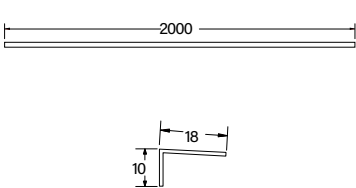
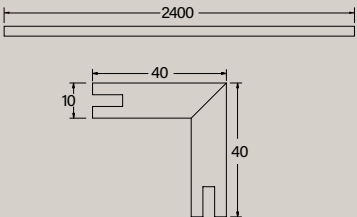
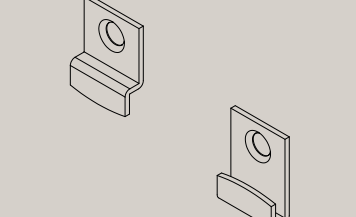

ACCESSORIES ACCESORIOS 配件		MEASURES MEDIDAS 测量	ACCESSORIES ACCESORIOS 配件		MEASURES MEDIDAS 测量
Skirting Zócalo 踢脚线 (5 piezas/box / 5 piezas/caja / 五个一盒) *Available in all Fiorwood colours. *Disponible en todos los colores Fiorwood *对所有Fiorwood系列的颜色适用		2400 x 80 x 15 mm 94.49" x 3.15" x 0.59"	Strip perimeter 40 Faja perimetral 40 条状周长40		2400 x 40 x 10 mm 94.49" x 1.57" x 0.39"
Board dilatation Junta dilatación 伸缩缝 *Available in all Fiorwood colours. *Disponible en todos los colores Fiorwood. *对所有Fiorwood系列的颜色适用。		1160 x 145 x 10 mm 45.67" x 5.71" x 0.39"	Strip perimeter 80 Faja perimetral 80 条状周长80		2400 x 80 x 10 mm 94.49" x 3.15" x 0.39"
Auction perimeter Remate perimetral 预装板材 *For wall installation. *Para instalación en pared. *适用于墙壁安装		2400 x 40 x 10 mm 94.49" x 1.57" x 0.39"	Auction perimeter inox Remate perimetral inox 不锈钢边界周长		2000 x 13 x 13 mm 78.74" x 0.51" x 0.51"
Landings Remate desnivel 地触 *For floor installation. *Para instalación en suelos. *适用于地板安装		2000 x 32 x 10 mm 78.74" x 1.26" x 0.39"	Landings inox Remate desnivel inox 不锈钢地触		2000 x 13 x 18,8 mm 78.74" x 0.51" x 0.74"
Square edge for treads Remate peldaño recto 方形边缘的踏板		2400 x 55 x 40 mm 94.49" x 2.17" x 1.57"	Edge cover inox Perfil cubrecorte inox 不锈钢边缘覆盖		2000 x 10 x 18 mm 78.74" x 0.39" x 0.71"
Angled auction perimeter Cantenera 直角边界周长		2400 x 40 x 40 mm 94.49" x 1.57" x 1.57"	Covering hook "H" Eganche revestimiento "H" 覆盖勾 "H" Covering Hook "L" Eganche revestimiento "L" 覆盖勾 "L"		25 x 15 x 5 mm 0.98" x 0.59" x 0.2" 18,18 x 15 x 5 mm 0.72" x 0.59" x 0.2"



Fior Design Spark 502x209
Oak Aquamarine

INSPIRATION

INSPIRACIÓN

灵感



Designer: HU RUI - Beijing

Fior+ 870x290 - 580x580 - 580x290
Oak Natural

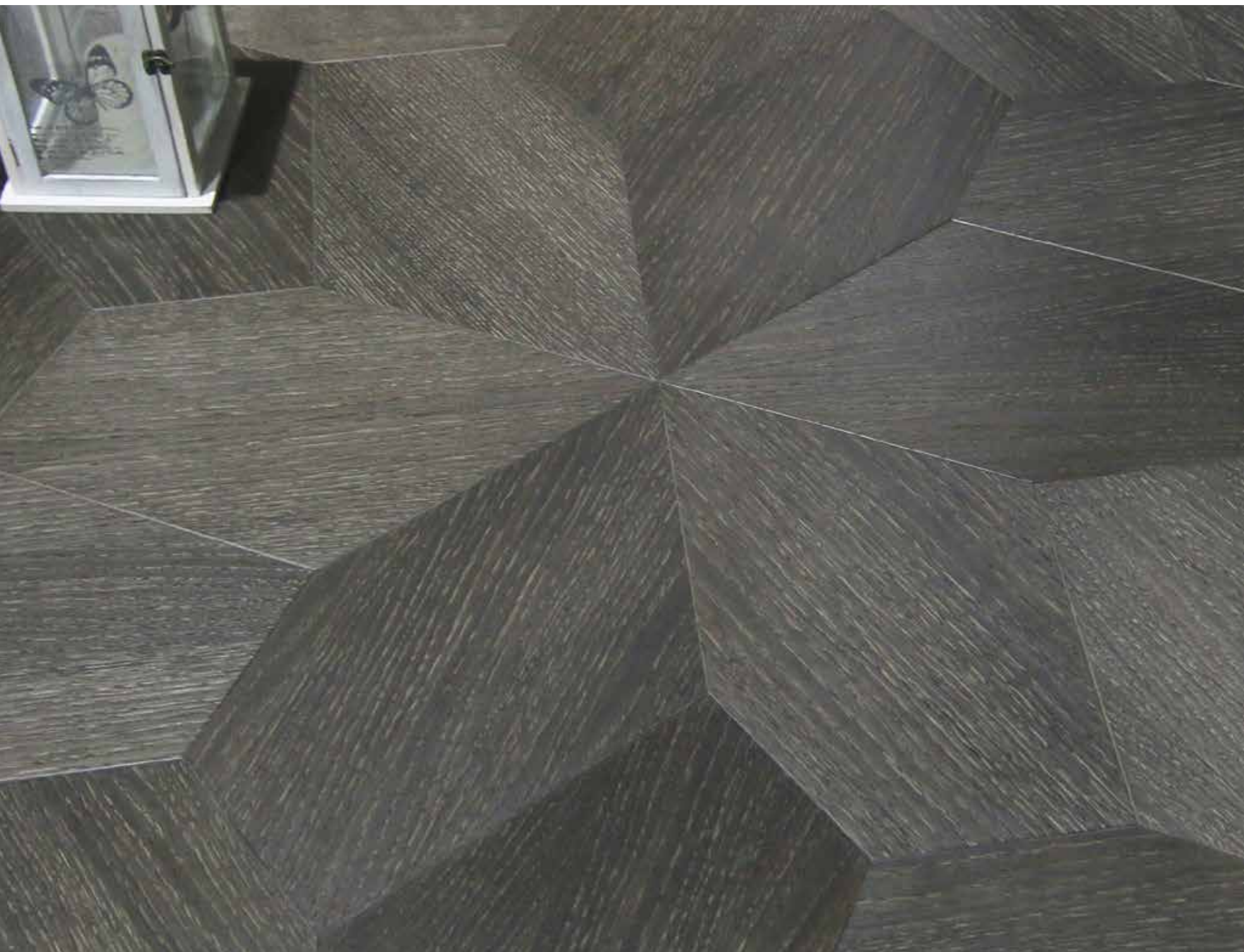

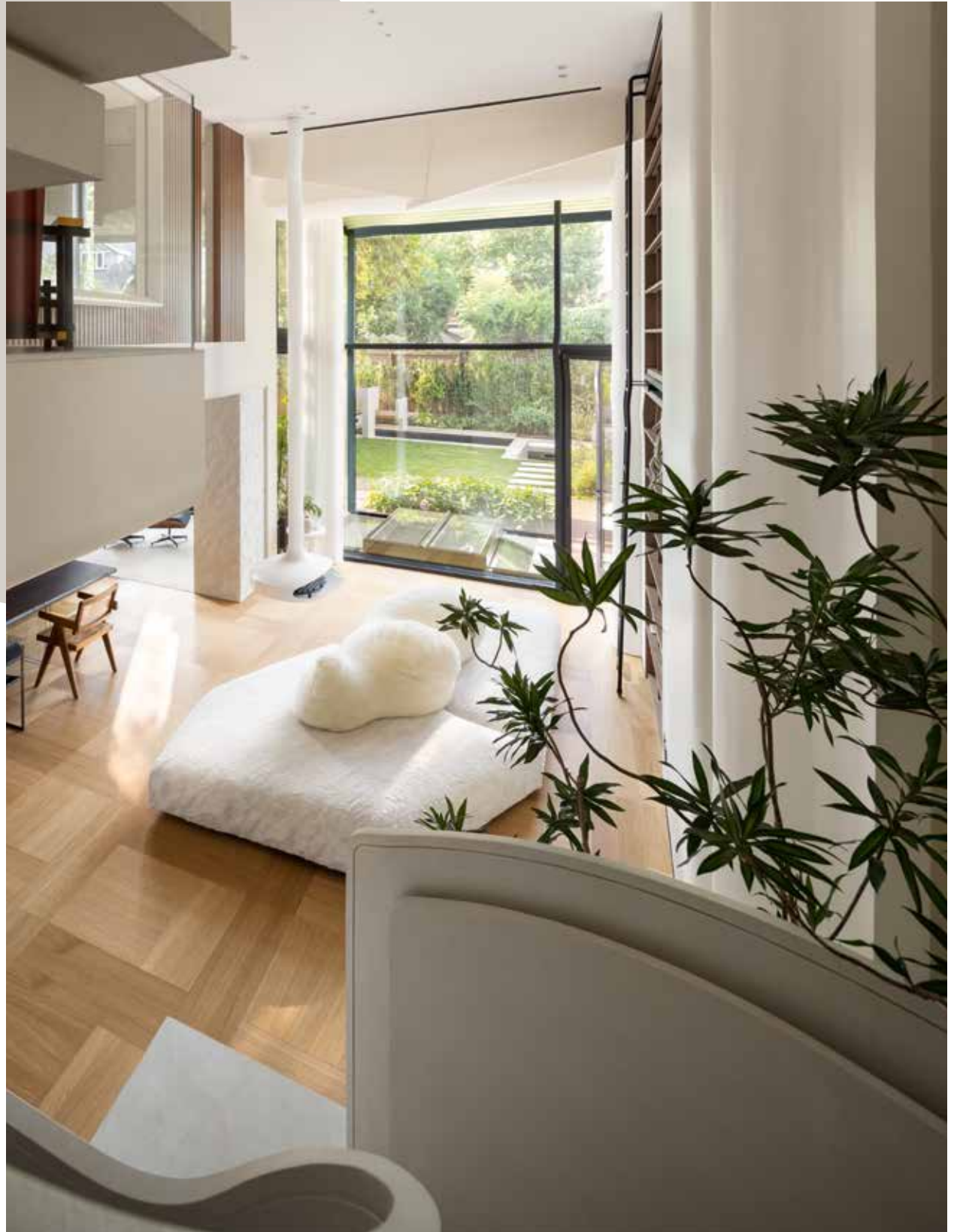



Fior Design Shuriken 290x290
Oak Extra White + Oak Botanic





With more than 100 years of experience in wood, STP® designs and produces, in our factory located in Vila-real (Castellón), wood flooring and wall covering, with our innovative LockSTP® system, patented worldwide.

Con más de 100 años de experiencia en la madera, STP® diseña y produce, en nuestra fábrica localizada en Vila-real (Castellón), pavimentos y revestimientos de madera con nuestro innovador sistema LockSTP®, patente mundial.

STP®设计和生产，木地板以及墙面装饰，STP®拥有超过100年的木材经验，我们的工厂位于西班牙瓦伦西亚，我们研发的创新安装系统 LockSTP®，获得全球专利



Creativity, passion for the well-done things and love for wood, are the pillars that move us towards solutions to our clients needs.

La creatividad, la pasión por el trabajo bien hecho y el amor por la madera son los pilares que nos mueven hacia las soluciones a las necesidades de nuestros clientes.

创造力、追求细节的热情以及对木材的热爱，是推动我们解决客户需求的支柱。

The LockSTP® system, thanks to its module and the engineering precision, guarantees a perfect union without the need of adhesives.

El sistema LockSTP®, gracias a que es modular y a la precisión de la mecanización, garantiza una unión perfecta sin la necesidad de adhesivos.

LockSTP®安装系统，是基于模块化和工程精度，保证了完美的结合，而不需要任何胶合剂



We are aware of the privilege of working with a natural material such as wood, which, more than ever, needs to be protected, which is why at STP® we carry out an eco-sustainable policy, limiting waste and supporting the renewal of the resources.

We are aware of the privilege of working with a natural material such as wood, which, more than ever, needs to be protected, which is why at STP® we carry out an eco-sustainable policy, limiting waste and supporting the renewal of the resources

我们意识到使用木材等天然材料的优势，这比以往任何时候都更需要得到保护，这就是为什么STP®执行生态可持续政策的原因，我们限制浪费资源以及支持资源更新。



Satisfied customers around the world trust us.

Clientes satisfechos de todo el mundo confían en nosotros.

让世界各地的客户满意并且信任我们！

The STP® material is unique, due to its technical characteristics and design, with a wide range of formats and many possible combinations between them, thanks to our LockSTP® system.

The STP® material is unique, due to its technical characteristics and design, with a wide range of formats and many possible combinations between them, thanks to our LockSTP® system.

STP®产品是独特的，由于其技术特点和设计理念，具有广泛多变的规格和层出不穷的组合方式，这都要归功于我们独有的LockSTP®安装系统。



Bicomponent epoxy-polyurethane adhesive completely odorless water-free and solvent-free, suitable for laying traditional or prefinished wooden floors on any kind of surfaces, also pre-existent and nonabsorbent ones (ceramic, marble, etc.). Eurobi 2C+ Solvent Free guarantees high workability, elasticity and a long time of use. Suitable on underfloor heating systems. The absence of solvents and the very low concentration of other substances volatile organic ensures greater safety for the user and compliance with environmental quality.

Adhesivo bicomponente de epoxi-poliuretano completamente inodoro, sin agua ni solventes, indicado para instalar pavimentos de madera tradicional o preacabada sobre cualquier tipo de superficie, incluyendo pavimentos preexistentes no absorbentes (cerámica, mármol, etc.). Eurobi 2C+ libre de solventes, garantiza una alta trabajabilidad, elasticidad y durabilidad. Indicado para suelo radiante. La ausencia de solventes y la muy baja concentración de otras sustancias orgánicas volátiles garantizan una mayor seguridad para el usuario y el respeto a la calidad ambiental.

双组分环氧聚氨酯粘合剂完全无味、无水和无溶剂，适用于在任何类型的表面上铺设传统或预制木地板，也适用于预先存在的和非吸水的（陶瓷、大理石等）。

Eurobi 2C+无溶剂保证了高可操作性、弹性和长时间使用。适用于地暖系统。缺乏溶剂和其他挥发性有机物质的浓度非常低，确保了用户的更大安全性和对环境质量的合规性。



EUROBI 2C⁺ Chemical-Physical characteristics (20°C - 60% R.H.)			
Component A appearance	Thick paste	Specific gravity of mix (UNI EN 542)	1,699 g/cm ³
Component B appearance	Liquid paste	Concentration of solvents	Zero VOC
Mixture viscosity (Brookfield rev.nr.7 50 rpm)	49000 mPa		
Mixing ratios and Times (20°C - 60% R.H.)			
Mixing ratio A + B	9 : 1 in weight	Set to traffic	24 h
Pot life	90 min.	Polishing	2 - 3 days
Adjustment time	8 - 10 h	Possible dilution	Max 100 ml P.E.P.P. promoter
Technical characteristics (20°C - 60% R.H.)			
Consumption (10 mm notched trowel)	1000 - 1500 gr/m ²	Application temp.	> 10°C < 35°C
Shear strenght (Rif. EN 14293)	> 3,5 N/mm ²		
ADHESIVE COMPLIANT UNI EN 14293			
Storage & Labeling			
Storage in original packaging sealed at T> 10 °C	12 months	Symbols of danger	Comp. A: Xi Comp. B: Xi
Packaging	Buckets 9,9 Kg + 1,1 Kg		Table 1



Mono-component adhesive based on silane polymers for elastic bonding of wooden floors. It is water and solvent free, it does not contain epoxy resins nor isocyanate. It is suitable for engineered wood floorings of any species and dimensions. It is also suitable for solid wood up to 140 mm width on any type of absorbent and non absorbent sub-floors. Thanks to its elasticity, it is particularly recommended on under-floor heating and cooling systems; it does not swell and has got goodsound proofing properties. Easy to use, high yield, no waste, easy to clean from hands and prefinished parquet, Euromono+ has no symbol of risk and a very low VOC content.







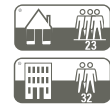

Adhesivo monocomponente basado en polímeros de silano para la unión elástica de pavimentos de madera. No contiene agua ni solventes, ni tampoco resinas epoxi ni isocianato. Indicado para pavimentos de madera mecanizada de cualquier tipo y tamaño. También está indicado para madera maciza de hasta 140 mm de ancho sobre cualquier tipo de subsuelo, absorbente y no absorbente. Gracias a su elasticidad, se recomienda particularmente en los sistemas de climatización por suelo radiante/refrescante; no se hincha y tiene propiedades insonorizantes. Fácil de usar, de un alto rendimiento, sin desperdicio. Es fácil de limpiar de las manos y del parquet preacabado, Euromono+ no simboliza ningún riesgo y tiene un contenido de VOC muy bajo.

基于硅烷聚合物的单组分粘合剂，用于木地板的弹性粘合。它不含水和溶剂，不含环氧树脂和异氰酸酯。它适用于任何种类和尺寸的工程木地板。它也适用于任何类型的吸水性和非吸水性子地板上宽度高达140毫米的实木。由于其弹性，它特别推荐用于地暖和冷却系统；它不会膨胀，并具有良好的隔音性能。易于使用，产量高，无浪费，易于用手和预成品镶木地板清洁，Euromono+没有风险的象征，挥发性有机化合物含量非常低。



EUROMONO⁺ Physical characteristics (20°C - 60% R.H.)			
Aspect	Thixotropic paste	Viscosity (Brookfield spindle 7 - 50 rpm)	35000 mPa.s
Density	1,7 g/cm ³		
Times (20°C - 60% R.H.)			
Opening time	40 - 60 min	Light traffic	6 - 10 hours
Hardening time	8 - 10 h	SandingW	2 - 3 days
Technical characteristics (20°C - 60% R.H.)			
Yield (spatula 8 mm)	700 - 1200 gr/m ²	Water resistance	excellent
Shear strenght (UNI EN 14293)	1,2 N/mm ²	Shear elongation factor (UNI EN 14293)	> 2
Chemical resistance	excellent	Application temperature	> + 10°C
Storage & Labeling			
Shelf-life in original unopened packaging at ambient temperature in a fresh and dry space	12 months	Symbols of risk	None
Packaging	Bucket of 15 Kg		Table 2



SIMB	FEATURES CARACTERISTICAS 特性	NORM NORMA 标准	NOR M VALUE VALORES NORMA 标准的价值	STP VALUE VALORES STP stp价值
	Level of Use Clase de Uso 使用等级	EN 685	-	Domestic - 23 Commercial - 32 
	Abrasion Resistance Resistencia a la Abrasión 耐磨性	EN 14354 Anexo D	4000 revolutions	5000 revolutions
	Impact Resistance Resistencia al Impacto 防撞性	EN 14354 Anexo C	EC2 > 1200 mm	EC2
	Formaldehyde Emission Emisión Formaldehído 甲醛释放	EN 717-2:95	E1	E1 (<3,5mg/h.m ²)
	Biological Durability Durabilidad Biológica 生物持久性	EN 335-1 y 2	-	Clase 1
	Reaction of Fire Reacción al Fuego 防火等级	EN 13501	-	Clase C - fl S1
	Skid Resistance Resistencia al Deslizamiento 防滑性	EN 13893	-	Clase DS
	Thermal Conductivity Conductividad Térmica 导热系数	EN 12524	-	0,17 W/mk
	Breaking Strength (Maximun load) Resistencia a la rotura (Carga máxima) 断裂强度 (最大负荷)	-	-	PND
	CE certicate Certificado CE CE认证	EN 1432:2006	SI	SI
	Density Densidad 密度	-	-	706 (26) Kg/m ³
	Dimensional Stability Estabilidad Dimensional 密稳定性	EN 1910	-	Paralelo - Paralelo - Paral. 0,13 mm Perpend - Perpendicularare - Perp. 0,66 mm
	Moisture Content Contenido en Humedad 含水量	-	-	9,90 (0,74) %
	VOCs emission, classification according to French VOC legislation Emisión de VOC, clasificación según la legislación francesa de VOC 挥发性有机化合物排放, 依据法国VOC 法规进行分类	ISO 16000-6:2006	A+ = < 1000 µg/m ³	28 µg/m ³ 

TECHNICAL FEATURES

INFORMACIÓN TÉCNICA

技术特性

PRODUCT / PRODUCTO PRODOTTO / 产品

Three layers pavement
and coating
Pavimento y revestimiento
tricapa
三层漆面

SUPPORT / SOPORTE/ SUPPORTO / 支持

7 alternating layers of
FSCFSC engineered
plywood
7 capas de madera
contrachapada
FSC mecanizadas
7层纵横交替的FSC胶合板

THICKNESS / ESPESOR 厚度

10 mm (0,6+9+0,6)

INSTALLATION / INSTALACIÓN/ 安装

Floating (without glue) or
glued down
Flotante sin cola o
encolado
悬浮式 (无胶) 或胶合

TECHNOLOGY/ TECNOLOGÍA/ 技术支持

LockSTP / T&G
LockSTP锁扣或T&G传统
锁扣

PACKING FIORWOOD V2										20/03/2023
FORMAT	SQM/PC	SQM/BOX	PC/BOX	WEIGHT/BOX	PC/PAL.	BOX/PAL.	SQM/PAL.	MES/PALLETS	F/C	WEIGHT/PAL.
Fior⁺										
290x290	0,0841	2,3548	28	17kg	728	26	61,2248	1220x620x1130	F13C2	460kg
580x290	0,1682	2,3548	14	17kg	364	26	61,2248	1220x620x1130	F13C2	460kg
580x580	0,3364	2,3548	7	17kg	182	26	61,2248	1220x620x1130	F13C2	460kg
870x290	0,2523	3,0276	12	22kg	336	28	84,7728	1220x900x1050	F14C2	640kg
1160x290*	0,3364	3,3640	10	31kg	170	18	57,1880	1220x620x1000	F18C1	430kg
1160x580*	0,6728	3,3640	5	31kg	85	18	57,1880	1220x620x1000	F18C1	430kg
Tavole[®]Fior										
580x145	0,0841	2,3548	28	17kg	728	26	61,2248	1220x620x1130	F13C2	460kg
870x145	0,1262	3,0288	24	22kg	672	28	84,8064	1220x900x1050	F14C2	640kg
1160x145	0,1682	3,3640	20	31kg	340	18	57,1880	1220x620x1000	F18C1	435kg
1160x195	0,2262	3,3930	15	31kg	255	17	57,6810	1200x640x1130	F17C1	430kg
2320x195	0,4524	3,6192	8	26kg	320	40	144,7680	2360x1090x750	F8C5	1095kg
2320x145	0,3364	3,0276	9	22kg	450	50	151,3800	2360x1000x770	F10C5	1145kg
FiorChevron[®]										
410x145	0,0595	1,6660	28	12kg	728	26	43,3160	1220x620x1130	F13C2	330kg
580x145	0,0841	1,8502	22	13kg	660	30	55,5060	1050x910x1100	F6C5	430kg
580x205	0,1189	1,9024	16	14kg	480	30	57,0720	1105x910x1100	F6C5	430kg
870x145	0,1262	2,7764	22	21kg	528	24	66,6336	1105x910x1100	F6C4	505kg
870x205	0,1784	2,8544	16	21kg	384	24	68,5056	1105x910x1100	F6C4	520kg

*For FiorRhombus pattern, please, consider the same packing as Fior+ 1160x290 mm; and for FiorTrencadis 10 the same as Fior+ 1160x580 mm.

Por favor, para FiorRhombus considere el mismo embalaje que para Fior+ 1160x290 mm, y para FiorTrencadis 10, el mismo que para Fior+ 1160x580 mm.

非凡木异形Rhombus，请参考非凡木正方形1160*290的包装规格；非凡木异形Trencadis 10，请参考非凡木正方形1160*580的包装规格

PACKING

PACKING / 包装

PACKING FIORWOOD V2										20/03/2023
FORMAT	SQM/PC	SQM/BOX	PC/BOX	WEIGHT/BOX	PC/PAL.	BOX/PAL.	SQM/PAL.	MES/PALLETS	F/C	WEIGHT/PAL.
Fior DESIGN®										
Triangle 580x580	0,1682	2,3548	14	17kg	364	26	61,2248	1220x620x1130	F13C2	460kg
Silhouette 783x580	0,3364	2,0184	6	16kg	168	28	56,5152	1220x820x1009	F14C2	465kg
Trapezium 580x145	0,0631	1,7668	28	12kg	728	26	45,9368	1220x620x1130	F13C2	330kg
Trapezium 870x145	0,1051	2,5224	24	18kg	672	28	70,6272	1220x900x1050	F14C2	520kg
Hexagon 290x251	0,0546	1,5288	28	14kg	392	26	39,7488	1220x620x1130	F13C2	380kg
Hexagon 580x502	0,2185	1,5295	7	11kg	182	26	39,7670	1200x610x1120	F13C2	300kg
Diamond 502x290	0,0728	1,5288	21	11kg	546	26	39,7488	1220x620x1130	F13C2	300kg
Morisco 290x290	0,0467	1,3076	28	9kg	728	26	33,9976	1220x620x1130	F13C2	255kg
Squama 290x290	0,0471	1,6485	35	11kg	910	26	42,8610	1220x620x1130	F13C2	320kg
Shuriken 290x290	0,0539	1,5092	28	11kg	728	26	39,2392	1220x620x1130	F13C2	300kg
Braid 580x145 A 580x145 B 615x410 Hex	0,0736 0,0736 0,1682	0,5152 0,5152 1,1774	7 7 7	15kg	182 182 182	26	57,4028	1200x620x1130	F13C2	430kg
Spike 416x285	0,1027	2,4648	24	19kg	672	28	69,0144	1220x900x1050	F14C2	520kg
Arrow 725x145	0,0946	2,2704	24	16kg	720	30	68,1120	1050x910x1100	F6C5	515kg
Spark 502x290	0,0850	2,0400	24	16kg	672	28	57,1200	1220x0900x1050	F14C2	430kg
Premium										
Trencadis 16 1160x580	0,6728	2,0184	3	18kg	51	17	34,3120	1220x620x1000	F17C1	470kg
Versailles 16 580x580	0,3364	1,6820	5	17kg	130	26	43,7320	1230x620x1150	F13C2	455kg

*For FiorRhombus pattern, please, consider the same packing as Fior+ 1160x290 mm; and for FiorTrencadis 10 the same as Fior+ 1160x580 mm.

Por favor, para FiorRhombus considere el mismo embalaje que para Fior+ 1160x290 mm, y para FiorTrencadis 10, el mismo que para Fior+ 1160x580 mm.

非凡木异形Rhombus，请参考非凡木正方形1160*290的包装规格；非凡木异形Trencadis 10，请参考非凡木正方形1160*580的



STP
Wood+ Flooring Industries
Central Offices & Factory Plant.
C/ Olocau del Rei 3D (transversal CV-20. km 2,5)
Apdo. correos / P.O. Box 211.
12540 Vila-real / Castellón / Spain
Tel. (34) 964 785 121
info@stp-woodflooring.com
www.stp-woodflooring.com

